



ENAPART



93 S Railroad Avenue Unit C
Bergenfield NJ 07621 USA
www.enapart.com
sales@enapart.com



Via del Canneto 35,
Borgosatollo, Brescia - Italia
www.enapart.it
vendite@enapart.it



Barbaros Mah. Ihlamur Bul. Aĝaoĝlu
My Newwork No:3/15 Ataşehir / İstanbul
www.enapart.net
satis@enapart.net



PRIVADA 10 B SUR #3908 COL.
ANZUREZ, C.P. 72530, PUEBLA, PUE
www.enapart.com.mx
sales@enapart.com.mx



Friedrich-Ebert-Anlage 36, 60325
Frankfurt am Main, Germany
www.enapart.de
anfrage@enapart.de



4 boulevard Carnot, 95400
villiers-le-bel, Paris, France
www.enapart.fr
sales@enapart.fr



65049, ОДЕСА, ВУЛИЦЯ ІВАНА
ФРАНКА, БУДИНОК 55, ПОВЕРХ 3
www.enapart.com.ua
sales@enapart.com.ua



MUNICIPIUL BUCUREȘTI, SECTOR 3,
B-DUL BASARABIA, NR.250, CORP P+5
www.enapart.ro
sales@enapart.ro



〒584-0023 大阪府富田林市若松町
東2丁目2番16号
www.enapart.co.jp
sales@enapart.co.jp



PLAZA NUESTRA SEÑORA DE LAS
NIEVES 12 ,LOCAL ,50012,ZARAGOZA
www.enapart.es
ventas@enapart.es



Складова база „Онџл“, Склад А2, п.к.
4006, гр. Пловдив, България
www.enapart.bg
sales@enapart.bg



3 Austin Mews, High Street, Hemel
Hempstead, HP1 3AF , United Kingdom
www.enapart.co.uk
sales@enapart.co.uk

REHOBOT®

MADE IN SWEDEN

POWER WITH HYDRAULICS

INDUSTRIAL PRODUCTS

PRODUCT OVERVIEW

Slipping clutches

	max. torque available at output shaft (cNm)	free wheel-/clutch torque (cNm)
Roller-type free wheel		
Single-way slipping clutches	150	4 ... 50 counter clockwise or clockwise direction possible
Two-way slipping clutches	40 ... 70	60 ... 175

Torque / ratio / life graph

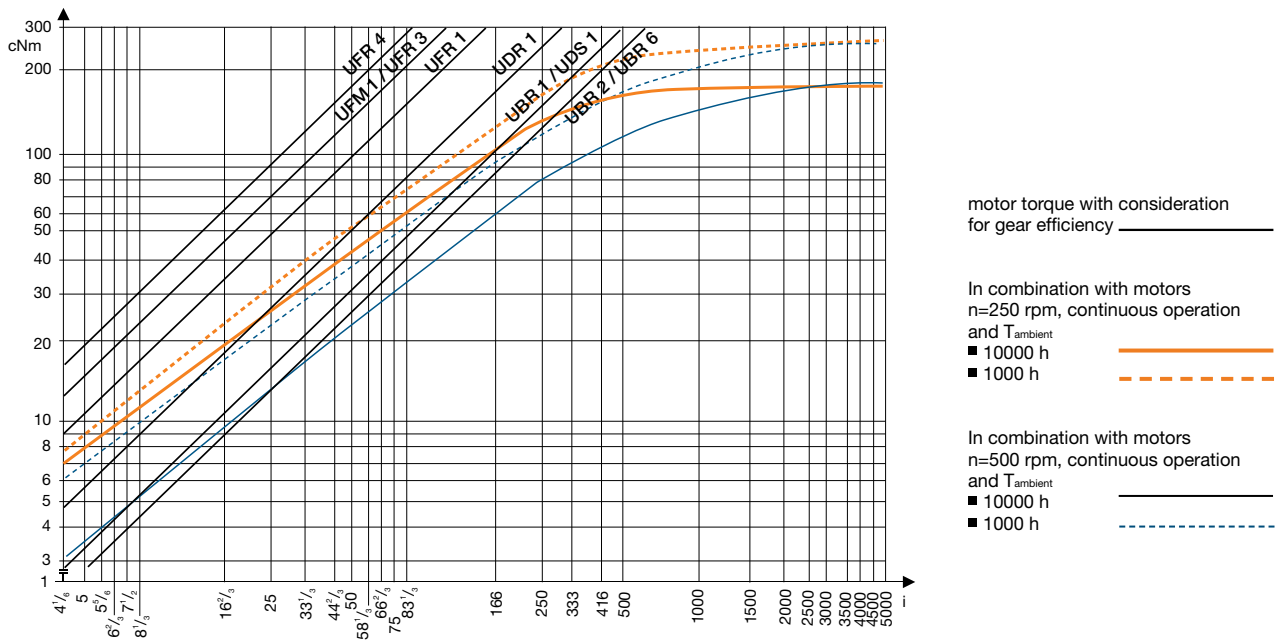

UGF

Dimensions (mm)	58 x 81
Height (mm)	17
Max. torque (cNm)	500
Ratios	4 ^{1/6} ... 5000
Internal slipping clutch	none
Standard shaft (mm)	∅ 8 x 12
Weight (g)	130
Motor combination	Series UC, UB, UD, UF



Standard Data

Mounting	any position
Axial thrust F _A	100 N
Lateral force F _R	400 N
Slipping clutches/free wheel	none
Slipping-/free wheel torque	cNm
Output shafts	∅ 8 x 12, other on request
Climatic class	wide-spread according to DIN IEC 60721-2-1
Ambient temperature operation	°C -15 ... +55
Ambient temperature storage	°C -40 ... +80

Ratios	4 ^{1/6}	8 ^{1/3}	16 ^{2/3}	20 ^{5/6}	25	30	41 ^{2/3}	50	62 ^{1/2}	83 ^{1/3}	100	125	166 ^{2/3}
	250	333 ^{1/3}	500	600	750	1000	1200	1500	4000	5000			

Order Reference

Type	Gearbox	UGF	100	N	N
Ratio	100				
Slipping clutch	N Without slipping clutch				
Shaft end	N ∅ 8 x 12, other on request				

Dimensions

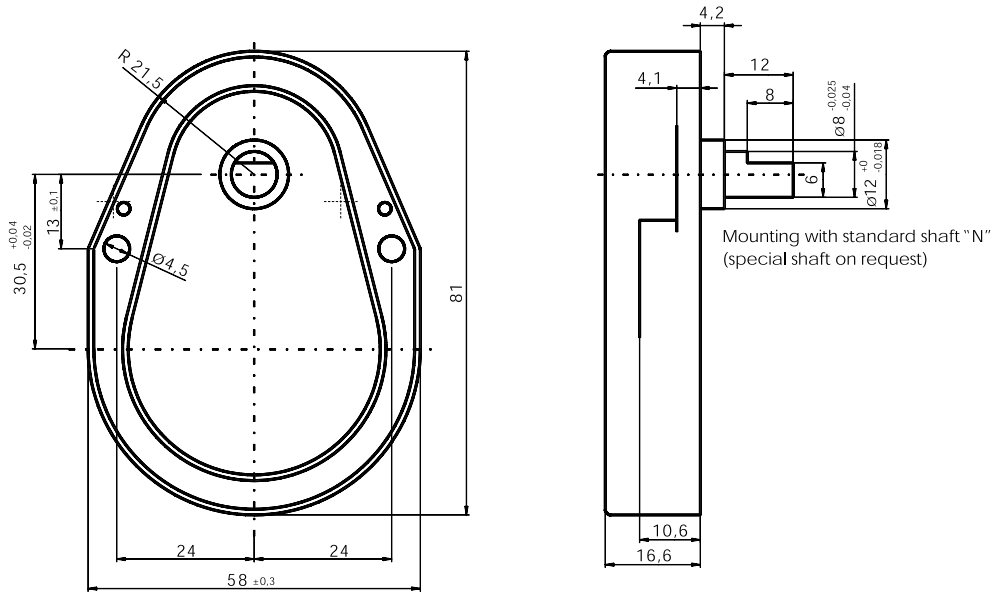

UDS 1..F

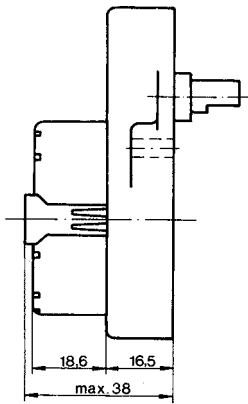

UBR 1/UBR 2..F

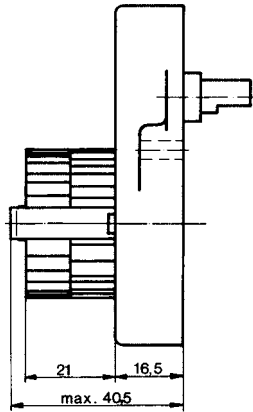

UDR 1..F

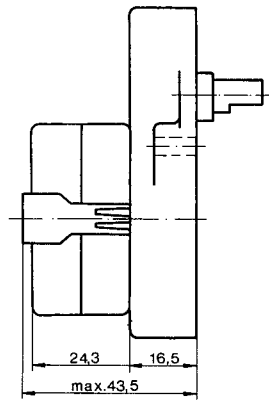

UFM 1/UFU 1/UFR 1..F

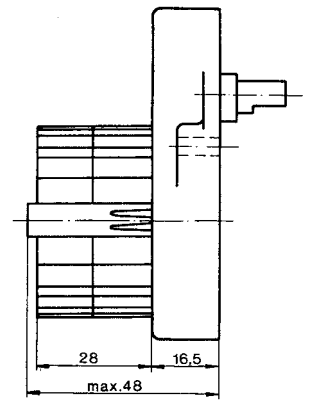

UFR 3..F

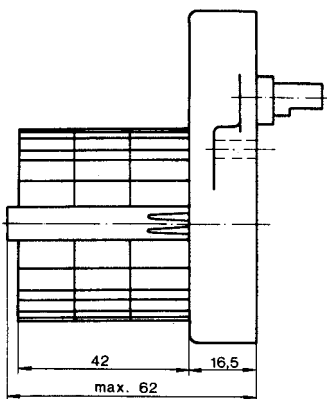

UFR 4..F

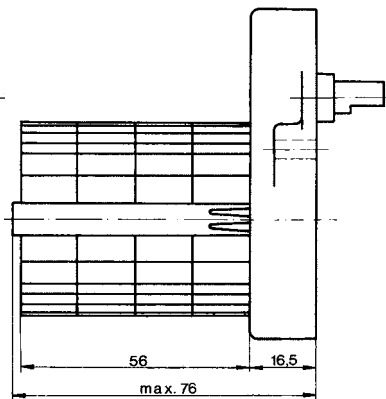

Torque / ratio / life graph

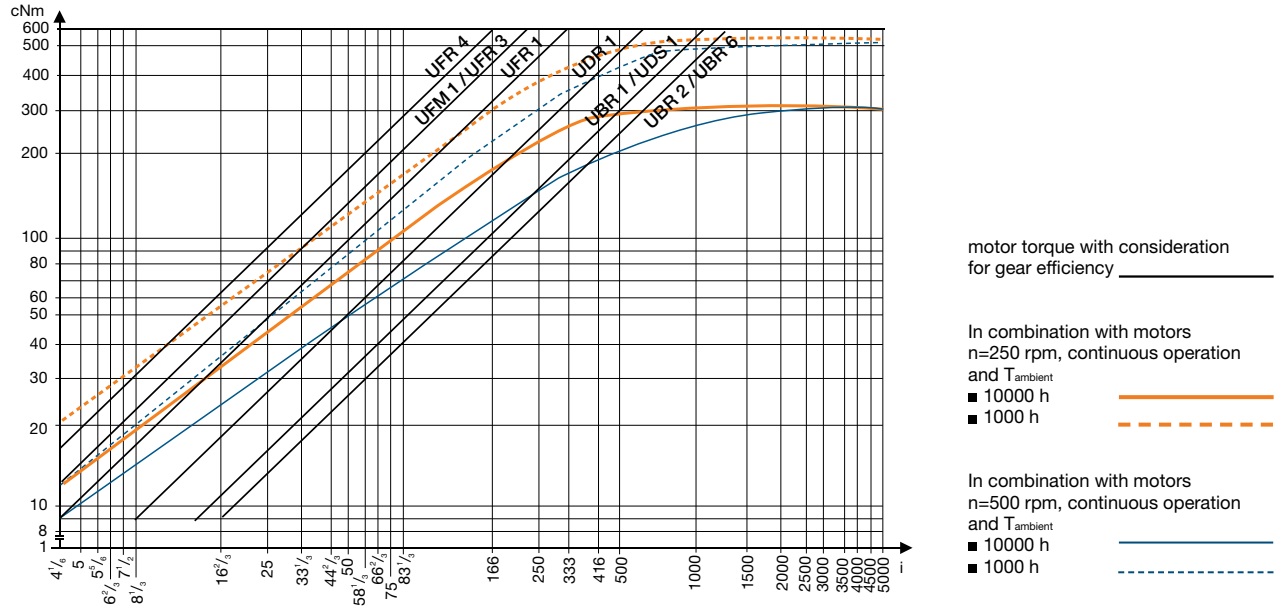

UGV

Dimensions (mm)	70 x 70
Height (mm)	17
Max. torque (cNm)	500
Ratios	8 ¹ / ₃ ... 2000
Internal slipping clutch	none
Standard shaft (mm)	Ø 8 x 12
Weight (g)	130
Motor combination	Series UB, UD, UF



Standard Data

Mounting	any position
Axial thrust F _A	100 N
Lateral force F _R	400 N
Output shafts	Ø 8 x 12, other on request
Climatic class	wide-spread according to DIN IEC 60721-2-1
Ambient temperature operation	°C -15 ... +55
Ambient temperature storage	°C -40 ... +80

Ratios 8¹/₃ 16²/₃ 25 41²/₃ 83¹/₃ 100 125 250 500 2000

Order Reference

Type	Gearbox	UGV	100	N	N
Ratio	100				
Slipping clutch	N Without slipping clutch				
Shaft end	N Ø 8 x 12, other on request				

All specifications are representative only and maybe subject to variation. For confirmation of values, please contact Johnson Electric. Please also read "Saia Motors Important Notes" on catalog or at www.johnsonelectric.com/SaiaMotorsNotes

Dimensions

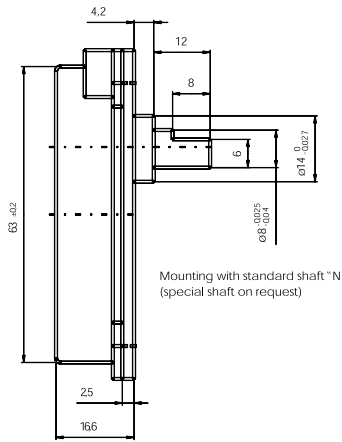
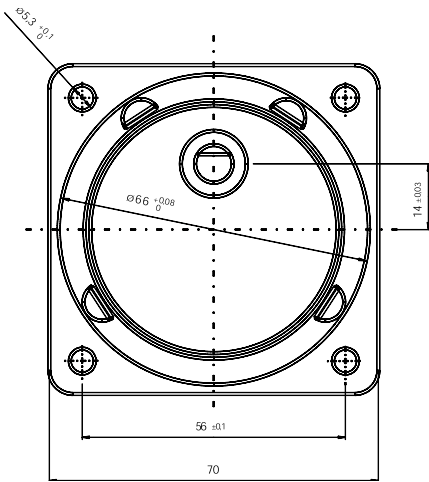

UDS 1..V

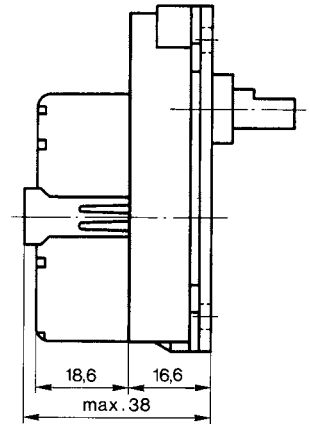

UBR 1/UBR 2..V

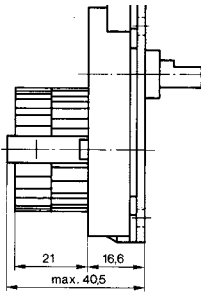

UDR 1..V

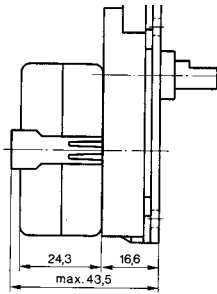

UFM 1/UFU1/UFR 1..V

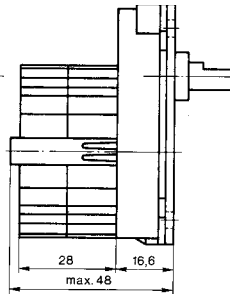

UFR 3..V

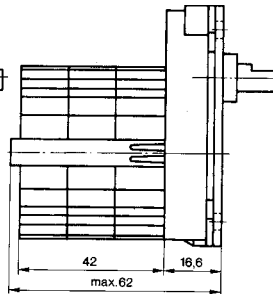

UFR 4..V

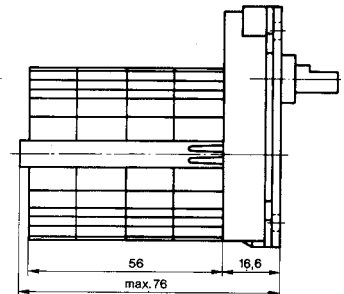

Torque / ratio / life graph

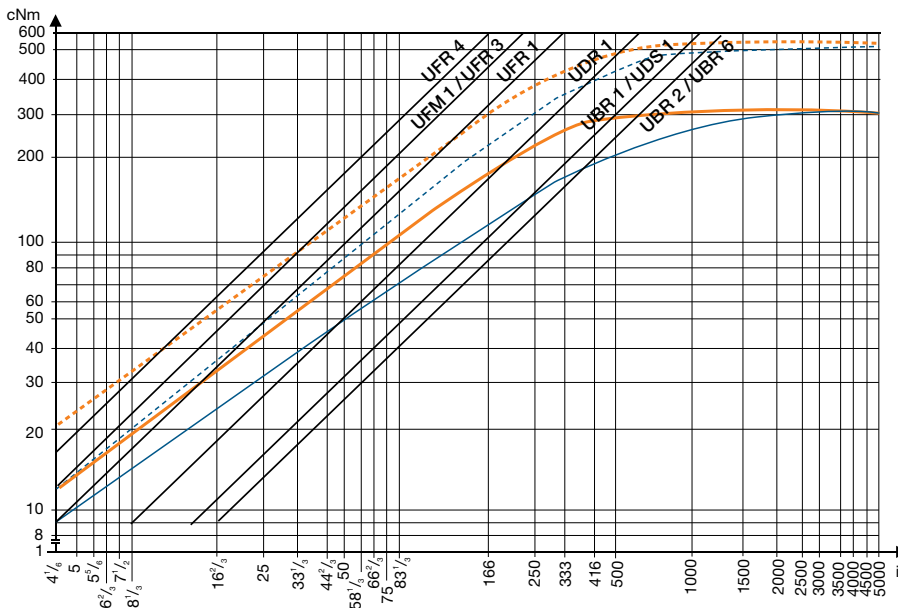

motor torque with consideration for gear efficiency _____

In combination with motors
n=250 rpm, continuous operation
and $T_{ambient}$

■ 10000 h ————
■ 1000 h - - - - -

In combination with motors
n=500 rpm, continuous operation
and $T_{ambient}$

■ 10000 h ————
■ 1000 h - - - - -

UGO/UGP

UGO/UGP (STG60/61)

Dimensions (mm)	65 x 65/68 x 68
Height (mm)	29.8–38
Max. torque (cNm)	600
Ratios	6 1/4 ... 3750
Internal slipping clutch	none
Standard shaft (mm)	∅ 8 x 22
Weight (g)	230–330
Motor combination	series UF and UP



UGO (STG 60)



UGP (STG 61)

Standard Data

Mounting	any position
Max. input speed*	3000 min ⁻¹
Max. output torque*	600 cNm
Max. input -and output power	please refer to table in Technical Data
Average back lash	unloaded 1.5 degree 2–4 stages with 6 Nm 3 degree 5–6 stages with 6 Nm 4 degree
Max. axial force F _A	30 N
Max. lateral force F _R , 12 mm from flange	80 N
Max. axial play	0.3 mm
Max. radial play	20 μm
Ambient temperature operation	–15 ... +60°C
Ambient temperature storage	–40 ... +100 °C

Ratio	6 1/4	12 1/2	18 3/4	25	31 1/2	37 1/2	46 7/8	50	62 1/2	75
	93 3/4	125	150	187 1/2	250	375	750	1500	2000	3750

* Depends on ratio, see next page

Order Reference

Type	Gearbox		STG60 UGO	6 1/4	M	N
Ratio	6 1/4					
Mounting layouts (fixing)	K	UGO				
	M	UGP	through holes			
	R	M4	threads on gearbox flange side			
	T	M4	threads on motor side			
	V	M4	threads on both sides			
	shaft end N ∅ 8 x 25, other upon request					
optional	motor pinion: see next pages		Motor Pinion Data			
	adaptor plate: see next pages		for adaptor plate			

All specifications are representative only and maybe subject to variation. For confirmation of values, please contact Johnson Electric. Please also read "Saia Motors Important Notes" on catalog or at www.johnsonelectric.com/SaiaMotorsNotes

Technical Data

Ratio	Stages *	Efficiency	Pinion type	Weight	Max. torque (Nm)	Max. input speed (rpm)
6 1/4	2	0.77	1	190	1.0	750
12 1/2	3	0.68	2	220	1.8	1500
18 3/4	3	0.68	3	220	2.7	2250
25	3	0.68	3	220	3.6	3000
31 1/4	3	0.68	4	220	4.5	3000
37 1/2	3	0.68	4	220	5.4	3000
46 7/8	4	0.60	3	250	6	3000
50	4	0.60	2	250	6	3000
62 1/2	4	0.60	2	250	6	3000
75	4	0.60	3	250	6	3000
93 3/4	4	0.60	3	250	6	3000
125	4	0.60	2	250	6	3000
150	4	0.60	3	250	6	3000
187 1/2	4	0.60	4	250	6	3000
250	5	0.53	2	280	6	3000
375	5	0.53	3	280	6	3000
750	5	0.53	4	280	6	3000
1500	6	0.46	4	310	6	3000
2000	6	0.46	4	310	6	3000
3750	6	0.46	4	310	6	3000

Additionally to the input speed limit: max. 120 rpm output speed

Technical Data valid for an ambient temperature operation: -15...+60°C

* Direction of rotation of output- and motor-shaft at
 2.4 and 6 stages - same
 3 and 5 stages - opposite

UGO/UGP

Dimensions UGO

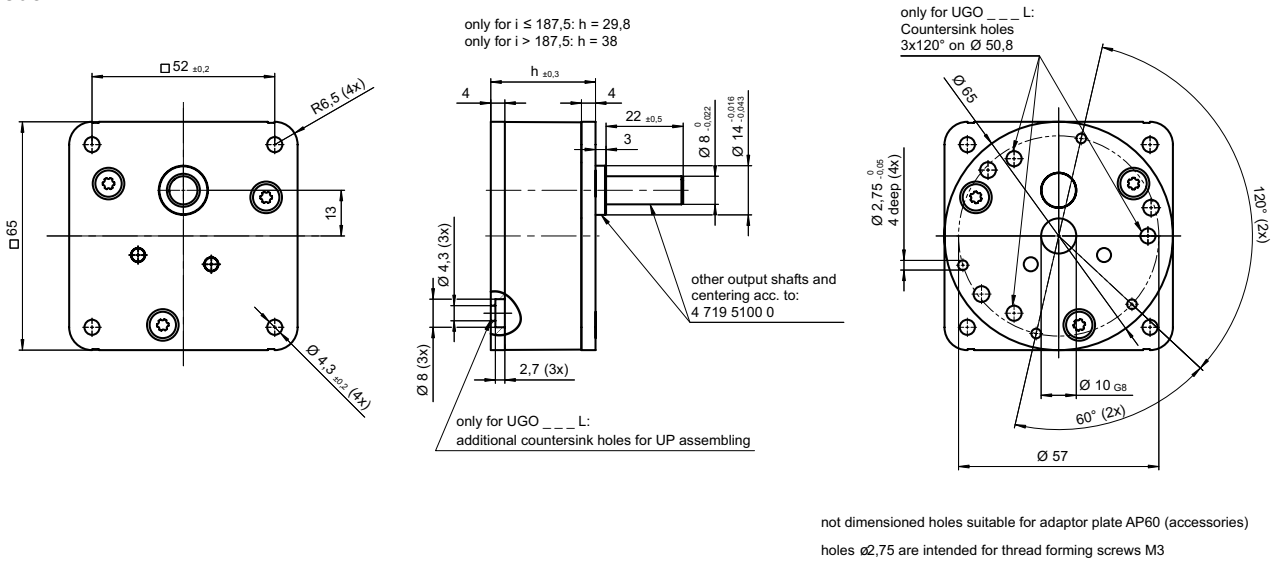

UGP

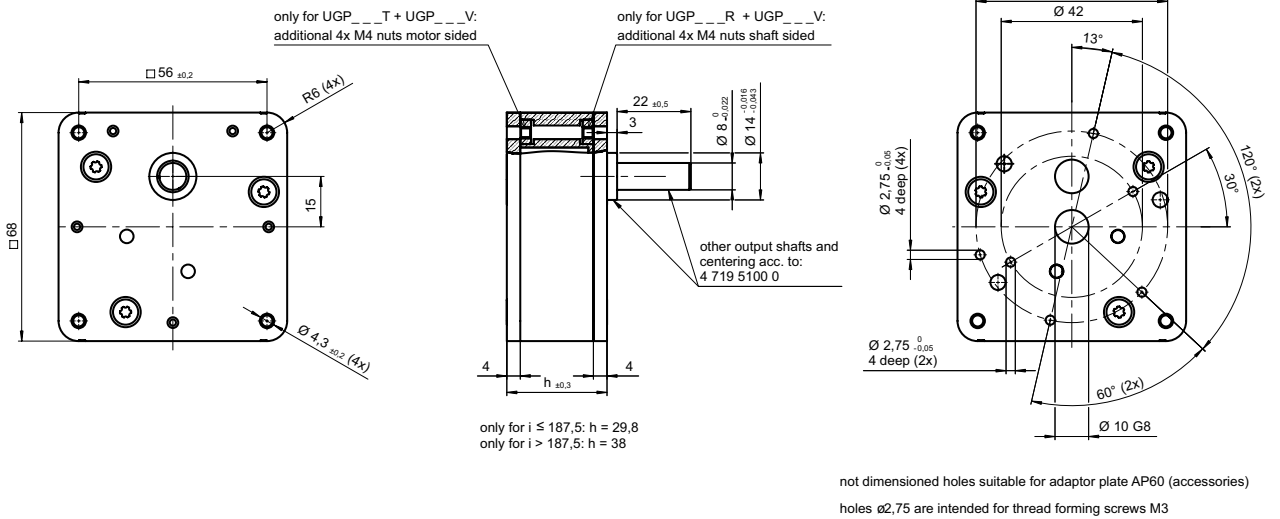

Other shafts on request

Motor Pinion Data UGO/P (STG 60/61)

pinion type	pinion length b	motor pinion with hole d: 022 100 004 ...			
		Ø2.5S7	Ø3S7	Ø4X7	Ø5S7
1	6	-	020	030	040
2	4.5	-	080	090	110
3	4.5	270	280	290	310
4	4.5	580	590	600	610

Dimensions for motor assembly

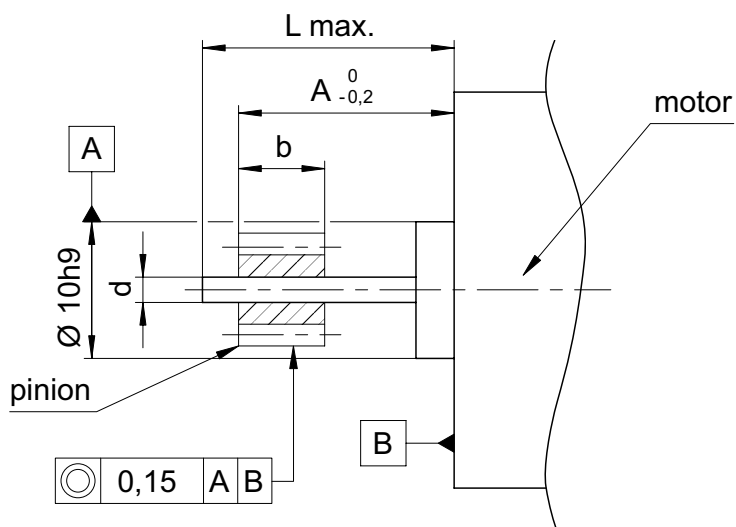

Pinion position	Dimension	A	L
2 gear stages		8,9	9,6
3-6 gear stages		7,6	7,6

AP 60

AP 60

Dimensions (mm) $\varnothing 64$

Height (mm) 6

Adaptor Plate Data AP 60

Adaptor plate	Motor type	Manufacturer	Centring $\varnothing D$	Order reference
AP 6012	G 30	Dunker	12	81B-001-002-010
AP 6022	G 42, GR 42		22	81B-001-002-016
AP 6014	M 28, M 32	GEFEG	14	81B-001-002-012
AP 6022	M 42, M 48		22	81B-001-002-016

Dimensions

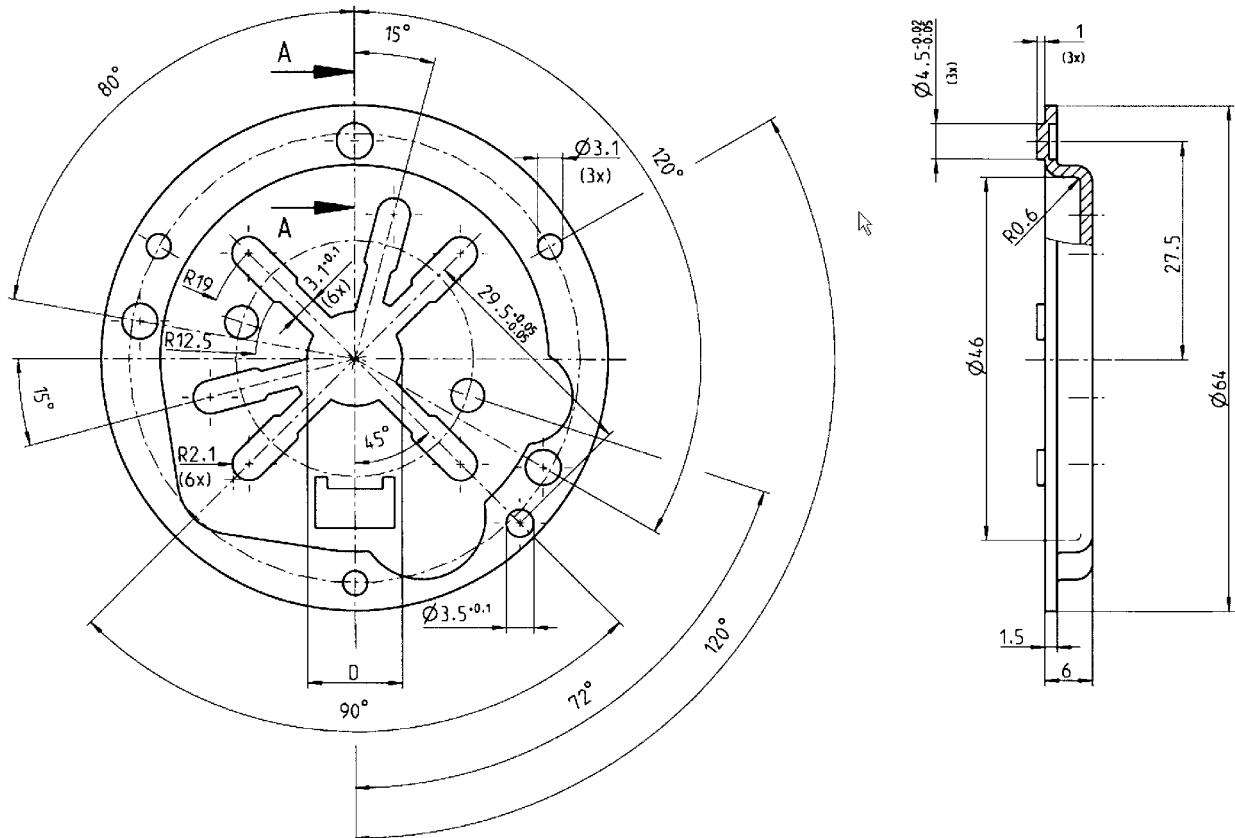

UGJ

Dimensions (mm)	65 x 107
Height (mm)	28
Max. torque (cNm)	1500
Ratios	4 ¹ / ₆ ... 36.000.000
Internal slipping clutch	none
Standard shaft (mm)	∅ 12 x 20
Weight (g)	480
Motor combination	Series UB, UD, UF



Standard Data

Mounting	any position
Axial thrust F _A	400 N
Lateral force F _R	600 N
Output shafts	∅ 12 x 20, other on request
Climatic class	wide-spread according to DIN IEC 60721-2-1
Ambient temperature operation	°C -15 ... +55
Ambient temperature storage	°C -40 ... +80

Ratios*	4 ¹ / ₆	8 ¹ / ₃	16 ² / ₃	33 ¹ / ₃	41 ² / ₃	50	66 ² / ₃	83 ¹ / ₃	100	125	150	166 ² / ₃	200
	250	500	1000	2000	2500	3000	4000	5000	6250	8333 ¹ / ₃	10000	12500	15000
	20000	25000	30000	37500	60000	75000	120000	150000	300000	375000	750000	1500000	1800000
	2250000	3000000	3600000	4500000	6000000	9000000	11250000	12000000	18000000	36000000			

* For ratio ≥ 2500 combination with UGD

Order Reference

Type	Gearbox	UGJ	100	N	N
Ratio	100				
Slipping clutch	N	Without slipping clutch			
Shaft end	N	∅ 12 x 20, other on request			

All specifications are representative only and maybe subject to variation. For confirmation of values, please contact Johnson Electric. Please also read "Saia Motors Important Notes" on catalog or at www.johnsonelectric.com/SaiaMotorsNotes

Dimensions

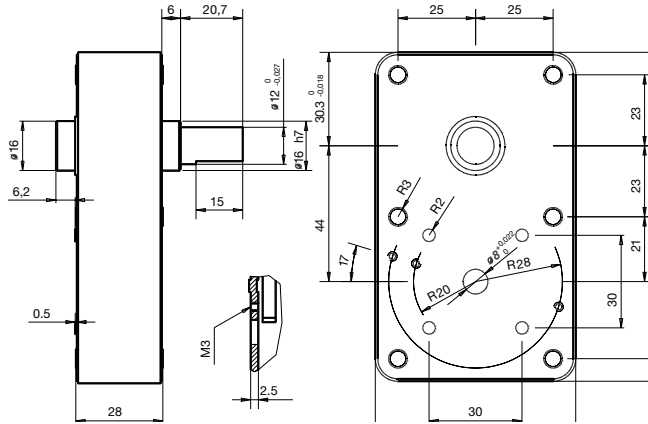

$i \leq 2000$

$i \geq 2500$

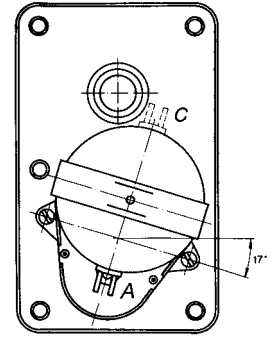
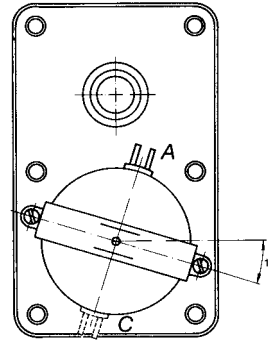

Lead outlet (A = standard position)

UDS 1..J, ≤ 2000

UDS 1..J, ≥ 2500

UBR 1/UBR 2..J, ≥ 2500

UDR 1..J, ≤ 2000

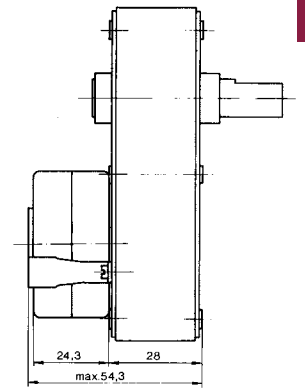
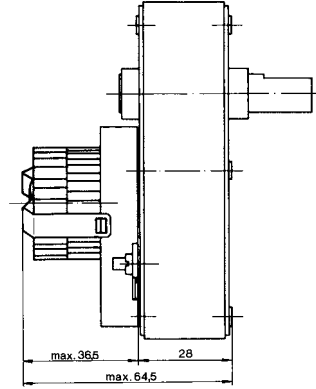
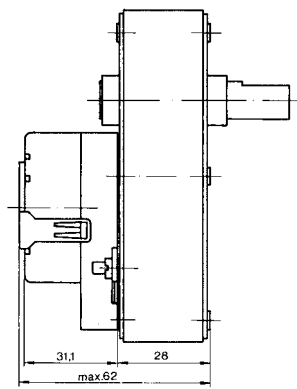
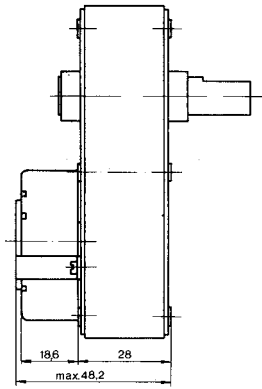

UDR 1..J, $i \geq 2500$

UFM 1/UFU 1/UFR 1..J, $i \leq 2000$

UFR 3..J, $i \leq 2000$

UFR 4..J, $i \leq 2000$

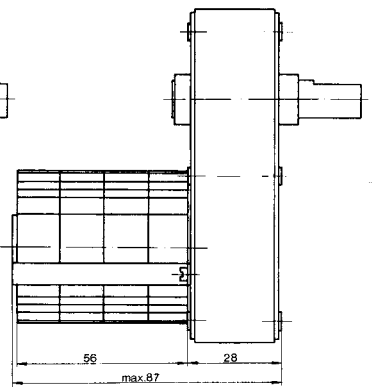
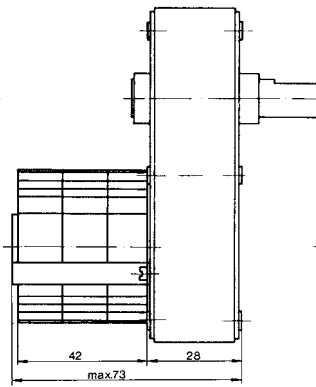
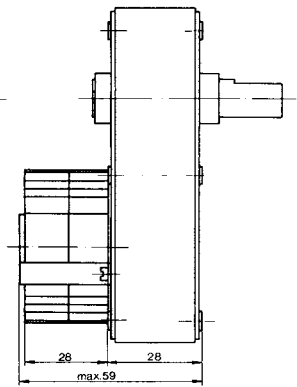
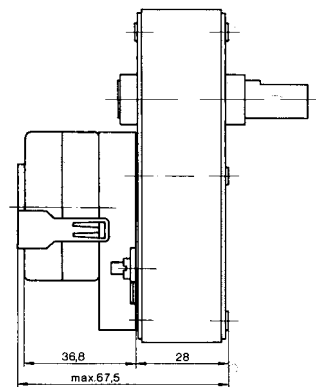

Torque / ratio / life graph

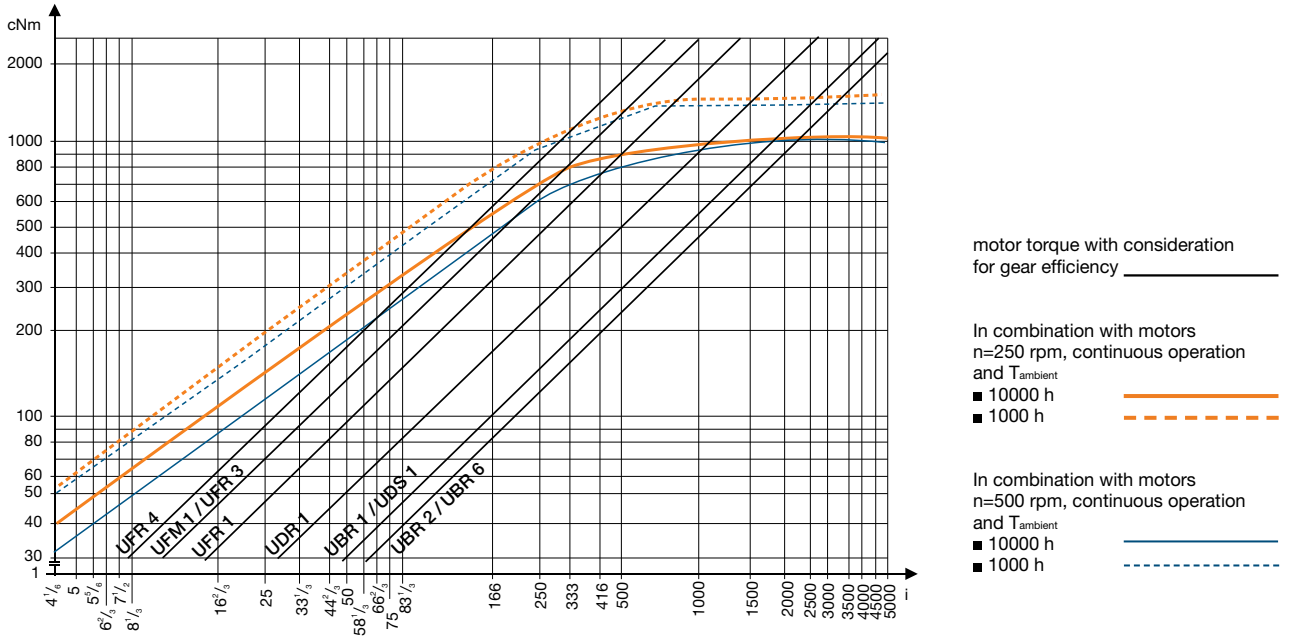

UGR (STG 200)

Dimensions (mm)	70 x 130
Height (mm)	38
Max. torque (cNm)	2000
Ratios	12.5 ... 375
Internal slipping clutch	none
Standard shaft (mm)	Ø 12 x 35
Weight (g)	depends on ratio
Motor combination	UP



Standard Data

Mounting	any position
Max. input speed *	3000 min ⁻¹
Max. output torque *	2000 cNm
Max. input -and output power *	please refer to table in Technical Data
Average back lash unload	0.75°
2/3 stages with 4/10 Nm	1.25°
4/5 stages with 15/20 Nm	2°
Max. axial force F _A	60 N
Max. lateral force F _R , 20 mm from flange	80 N
Max. axial play	0.3 mm
Max. radial play	83 µm
Ambient temperature operation	-15 ... +60°C
Ambient temperature storage	-40 ... +100 °C

Ratio	12 1/2	37 1/2	62 1/2	75	93 3/4	125	250	375
-------	--------	--------	--------	----	--------	-----	-----	-----

* Depends on ratio, see next page

Order Reference

Type	Gearbox	UGR	12 1/2	N	N
Ratio	12 1/2				
Mounting layouts	N	standard			
Shaft end	N	Ø 12 x 35, others upon request			
optional	motor pinion: see next pages	Motor Pinion Data			

All specifications are representative only and maybe subject to variation. For confirmation of values, please contact Johnson Electric. Please also read "Saia Motors Important Notes" on catalog or at www.johnsonelectric.com/SaiaMotorsNotes

Technical Data

Ratio	Stages *	Efficiency	Pinion type	Weight	Max. torque (Nm)	Max. input speed (rpm)
12 1/2	2	0.77	1	560	3.6	1500
37 1/2	3	0.68	2	580	9.9	3000
62 1/2	4	0.60	3	600	14.6	3000
75	4	0.60	4	600	17.5	3000
93 3/4	4	0.60	4	600	20	3000
125	4	0.60	4	600	20	3000
250	5	0.53	5	620	20	3000
375	5	0.53	2	620	20	3000

Additionally to the input speed limit: max. 120 rpm output speed

Technical Data valid for an ambient temperature operation: -15...+60°C

* Direction of rotation of output- and motor-shaft at
 2 and 4 stages - same
 3 and 5 stages - opposite

Dimensions other shafts on request

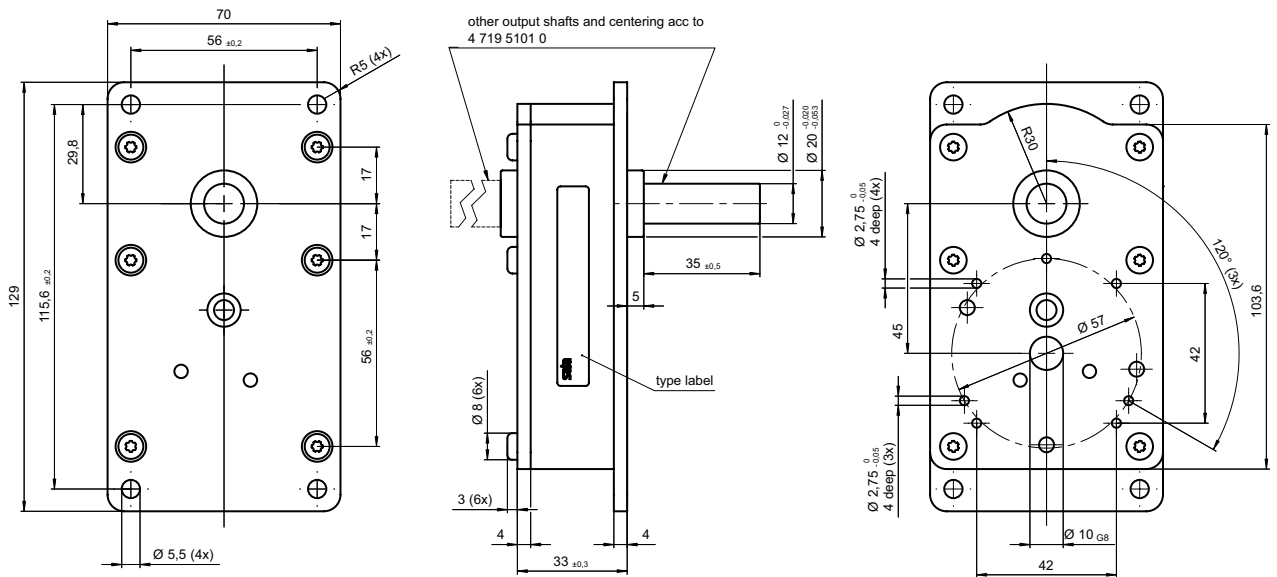

not dimensioned holes suitable for adaptor plate AP60 (accessories)
 holes Ø2,75 are intended for thread forming screws M3

Motor Pinion Data

pinion type	pinion length b	motor pinion with hole d: 022 100 020 ...		
		Ø3S7	Ø4X7	Ø5S7
1	11.5	-	130	140
2	6.8	280	290	300
3	11.5	360	370	380
4	11.5	400	410	-
5	6.8	-	250	260

Dimensions for motor assembly

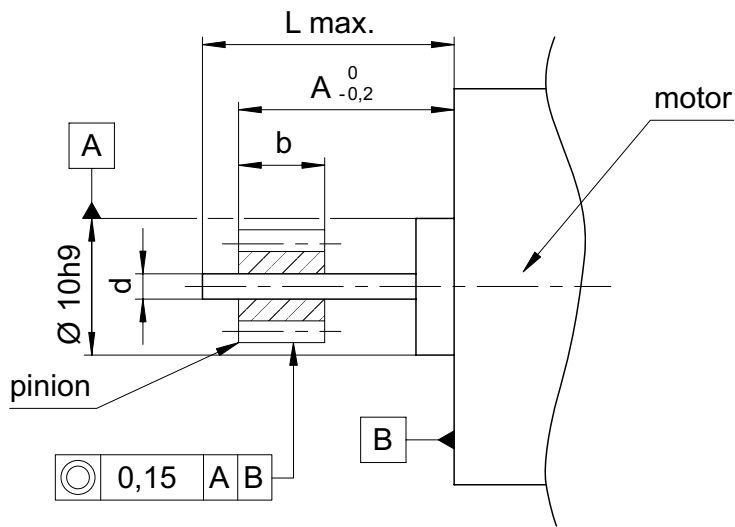

Pinion position	Dimension	A	L
2 gear stages		16.1	28
3 gear stages		10.3	10.3
4 gear stages		15.1	15
5 gear stages		10.9	11

Planetary Gearbox UGW

Dimensions (mm)	∅ 34 x 62,4 (without motor)
Max. torque (Nm)	4,5 (higher torque on request)
Ratio	541 (4 stages ; other ratios on request)
Standard shaft (mm)	∅ 8 x 21,3 with flat (other dimensions on request)
Motor combinations	Stepper/Synchronous motor UC ; DC motor HC3...6



Standard Data

Mounting	any position
Axial thrust FA	20 N (depend on lifetime spec ; higher force on request)
Lateral force FR	20 N (depend on lifetime spec ; higher force on request)
Climatic class	wide spread according to DIN IEC 60721-2-1
Ambient temperature operation	°C -20 ... +70
Ambient temperature storage	°C -20 ... +80
Weight	290 g (with DC motor HC313XLG)
Bearing	sintered bronze, self-lubricating

Order Reference

Example motor combination: with DC motor HC313XLG

Note: UGW is deliverable only as gearbox motor combination

Motor type	JP	DC Motor (brushed)	JP	3	A	N	X9	W	54C	N	F	N
Motor size	3	diameter 27.5 mm										
Motor version	A	13 V; no-load speed 7400 rpm										
Approval	N	standard										
Voltage	X9	13 Vdc										
Gearbox size	W	planetary gearbox diameter 34 mm										
Gear ratio	54C	541 (4 stages)										
Connection	N	standard										
	A	special										
Bearing/ Gear material	F	sintered bearing / metal gear wheels										
Shaft end	N	standard shaft ∅ 8 x 21.3 with flat										

Technical Data

Technical data of bare gearbox. Data of complete gearmotors on request

Stages	4
Ratio *	541
Max. torque [Nm] **	4,5
Short peak torque [Nm] **	6
Gear efficiency **	0,6

* Approximate value, precise values on request.

Other ratios between 3,8 ...541 on request.

** Approximate values, must be tested under specific operating conditions in application.

Higher values on request.

Dimensions

Example motor combination: with DC motor HC313XLG ; standard shaft

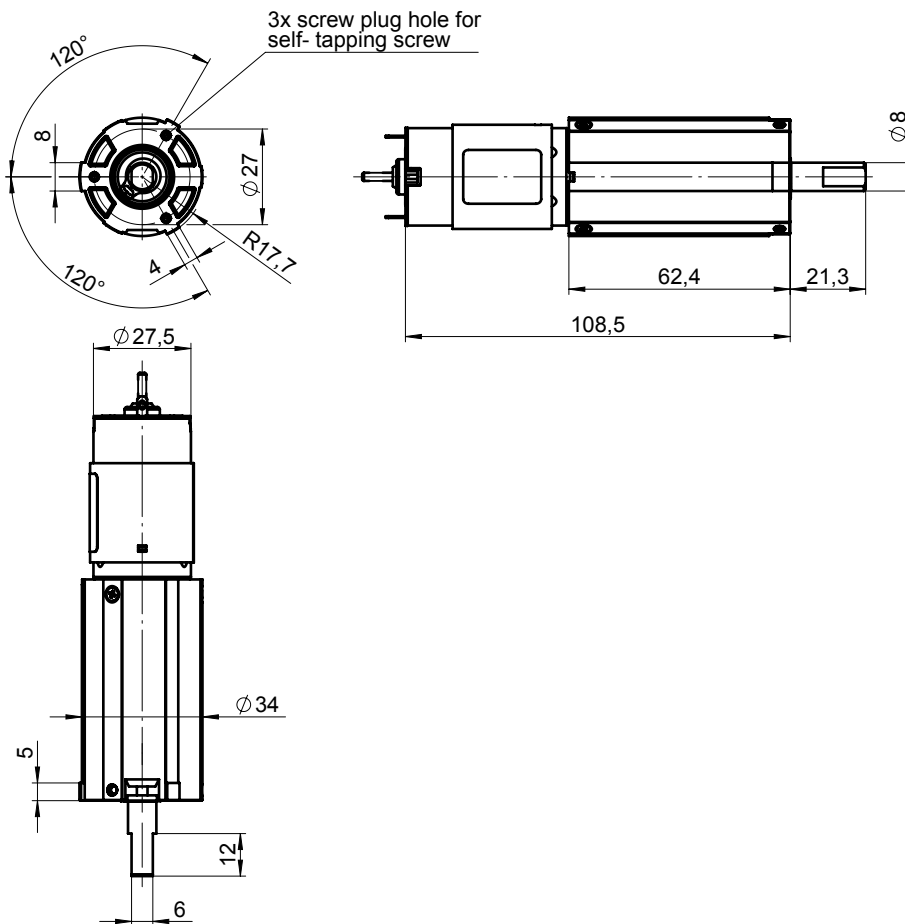

Gearboxes with DC & BLDC Motors

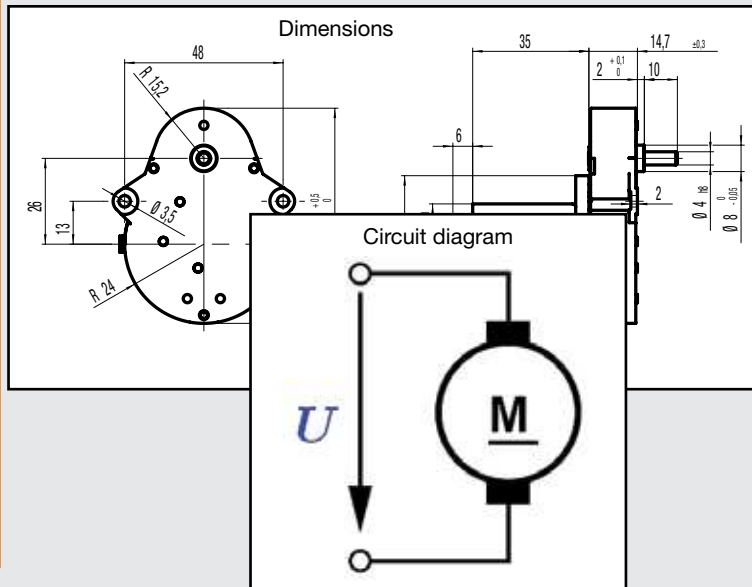

Gearbox UGM with DC Motor PC280LG



Voltage (Vdc)
Height (mm) 12/24

Max. torque
(cNm) 60

Standard Data

Ambient temperature operation	°C -10 ... +55
Ambient temperature storage	°C -20 ... +80
Rotor stalling	not permissible
Thermal class	130 (B) according to DIN EN 60085 : 2008
Approval	standard
Electrical connection	terminals
Mounting	any position
Weight	105 g
Axial thrust	20 N
Lateral force	100 N
Output shaft	∅ 4 × 10 mm (others on request)
Slipping clutch	no
Bearings	sintered bronze, self-lubricating

Order Reference

Motor type	JP	DC Motor (brushed)	JP	2	A	N	M4	M	40C	N	N	N
Motor size	2	diameter 24.4 mm										
Motor version	A	12 V; no-load speed 3600 rpm										
	B	24 V; no-load speed 2400 rpm										
Approval	N	standard										
Voltage	M1	12 Vdc										
	M4	24 Vdc										
Gearbox size	M											
Gear ratio	40C	400										
Connection	N	terminals, without lead wire										
	A	with lead wire and connector (on request)										
Slipping clutch	N	without slipping clutch										
Shaft end	N	standard shaft ∅ 4 × 10, others on request										

All specifications are representative only and maybe subject to variation. For confirmation of values, please contact Johnson Electric.
Please also read "Saia Motors Important Notes" on catalog or at www.johnsonelectric.com/SaiaMotorsNotes

Technical Data

Motor JP2A

Voltage supply	V	12
No-load motor speed	rpm	3600
Rated motor speed	rpm	2900
Rated motor current	mA	105
Rated motor torque	cNm	0.24

Gear ratio		120	150	240	300	400	500	1000	1500
Rated output speed	rpm	24	20	12	10	8	6	3	2
Rated output torque	cNm	18	23	36	45	60	60	60	60

Motor JP2B

Voltage supply	V	24
No-load motor speed	rpm	2400
Rated motor speed	rpm	1800
Rated motor current	mA	34
Rated motor torque	cNm	0.19

Gear ratio		120	150	240	300	400	500	1000	1500
Rated output speed	rpm	15	12	8	6	4.5	4	2	1.5
Rated output torque	cNm	14	18	28	36	48	59	60	60

All values approximate. Speed tolerance on request.
 Output torque permissible max. 60cNm.
 Continuous duty cycle permissible at rated torque.
 Higher torque at lower duty cycle on request.
 Lifetime on request.

Dimensions

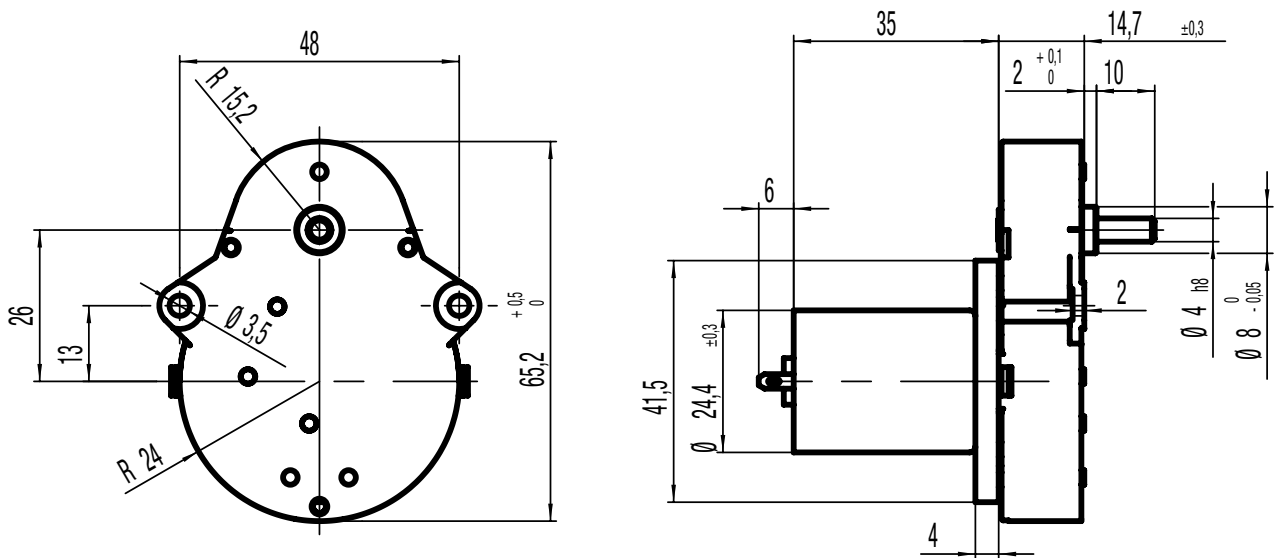

Gearbox with UGB DC Motor PC280LG

Voltage (Vdc)
Height (mm) 12/24

Max. torque
(cNm) 200



Standard Data

Ambient temperature operation	°C -10 ... +55
Ambient temperature storage	°C -20 ... +80
Rotor stalling	not permissible
Approval	standard
Electrical connection	terminals
Mounting	any position
Weight	200 g
Axial thrust	100 N
Lateral force	300 N
Output shaft	∅ 8 × 12 mm (others on request)
Slipping clutch	optional
Bearings	sintered bronze, self-lubricating

Order Reference

Motor type	JP	DC Motor (brushed)	JP	2	A	N	M4	B	30C	N	N	N
Motor size	2	diameter 24.4 mm										
Motor version	A	12 V; no-load speed 3600 rpm										
	B	24 V; no-load speed 2400 rpm										
Approval	N	standard										
Voltage	M1	12 Vdc										
	M4	24 Vdc										
Gearbox size	B											
Gear ratio	30C	300										
Connection	N	terminals, without lead wire										
	A	with lead wire and connector (on request)										
Slipping clutch	N	without slipping clutch										
Shaft end	N	standard shaft ∅ 8 × 12, others on request										

All specifications are representative only and maybe subject to variation. For confirmation of values, please contact Johnson Electric.
Please also read "Saia Motors Important Notes" on catalog or at www.johnsonelectric.com/SaiaMotorsNotes

Technical Data

Motor JP2A

Voltage supply	V	12
No-load motor speed	rpm	3600
Rated motor speed	rpm	2900
Rated motor current	mA	105
Rated motor torque	cNm	0.24

Gear ratio		150	200	300	500	600	750	1000	1500
Rated output speed	rpm	20	15	10	6	5	4	3	2
Rated output torque	cNm	23	30	45	75	90	115	150	200

Motor JP2B

Voltage supply	V	24
No-load motor speed	rpm	2400
Rated motor speed	rpm	1800
Rated motor current	mA	34
Rated motor torque	cNm	0.19

Gear ratio		150	200	300	500	600	750	1000	1500
Rated output speed	rpm	12	9	6	4	3	2.5	2	1.5
Rated output torque	cNm	18	24	36	59	70	90	120	180

All values approximate. Speed tolerance on request.
 Output torque permissible max. 200cNm.
 Continuous duty cycle permissible at rated torque.
 Higher torque at lower duty cycle on request.
 Lifetime on request.
 Other gear ratios on request.

Dimensions

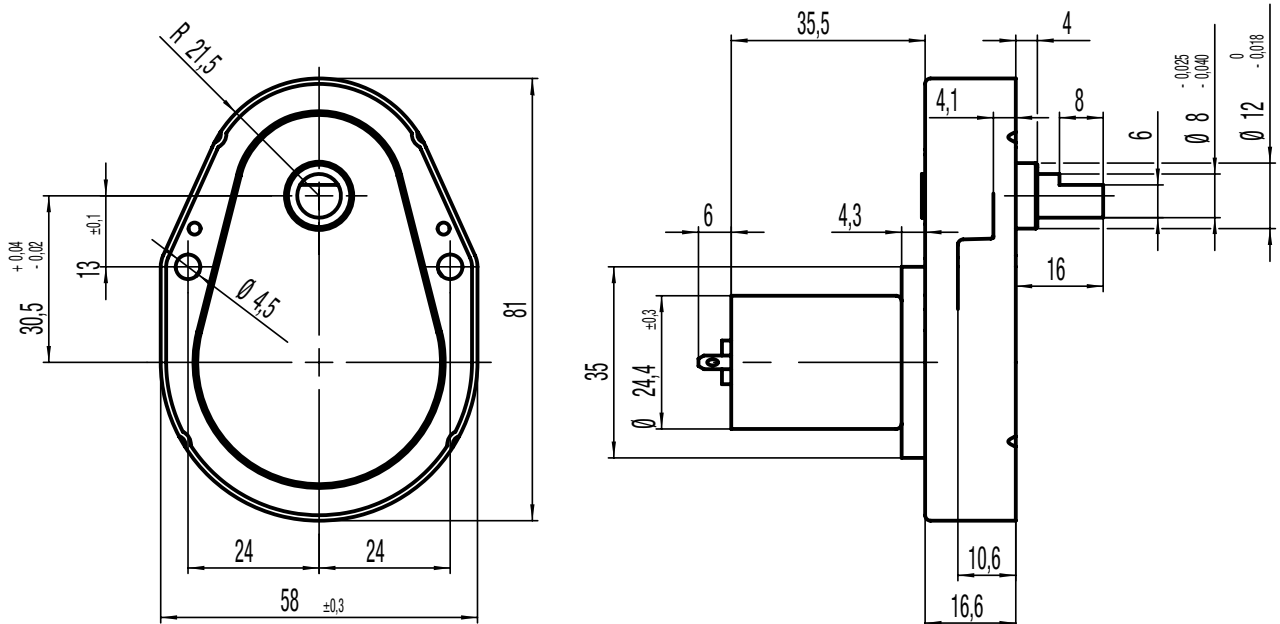

UGF-DC

Gearbox UGF with DC Motor HC485G



Voltage (Vdc) 12/24

Max. torque
(cNm) 400

Standard Data

Ambient temperature operation	°C -10 ... +55
Ambient temperature storage	°C -20 ... +80
Rotor stalling	not permissible
Approval	standard
Electrical connection	terminals
Mounting	any position
Weight	290 g
Axial thrust	100 N
Lateral force	400 N
Output shaft	∅ 8 × 12 mm (others on request)
Slipping clutch	no
Bearings	sintered bronze, self-lubricating

Order Reference

Motor type	JP	DC Motor (brushed)	JP	4	A	N	M4	F	33C	N	N	N
Motor size	4	diameter 31.2 mm										
Motor version	A	12 V; no-load speed 4500 rpm										
	B	24 V; no-load speed 4600 rpm										
Approval	N	standard										
Voltage	M1	12 Vdc										
	M4	24 Vdc										
Gearbox size	F											
Gear ratio	33C	333										
Connection	N	terminals, without lead wire										
	A	with lead wire and connector (on request)										
Slipping clutch	N	without slipping clutch										
Shaft end	N	standard shaft ∅ 8 × 12, others on request										

All specifications are representative only and maybe subject to variation. For confirmation of values, please contact Johnson Electric.
Please also read "Saia Motors Important Notes" on catalog or at www.johnsonelectric.com/SaiaMotorsNotes

Technical Data

Motor JP2A

Voltage supply	V	12
No-load motor speed	rpm	4500
Rated motor speed	rpm	3700
Rated motor current	mA	520
Rated motor torque	cNm	1.0

Gear ratio		125	166	250	333	500	750	1000	1200
Rated output speed	rpm	30	22	15	11	7.5	5	3.7	3.1
Rated output torque	cNm	80	100	150	200	300	400	400	400

Motor JP2B

Voltage supply	V	24
No-load motor speed	rpm	4600
Rated motor speed	rpm	3900
Rated motor current	mA	260
Rated motor torque	cNm	1.0

Gear ratio		125	166	250	333	500	750	1000	1200
Rated output speed	rpm	31	23	16	12	8	5.2	3.9	3.2
Rated output torque	cNm	80	100	150	200	300	400	400	400

All values approximate. Speed tolerance on request.
 Output torque permissible max. 400cNm.
 Continuous duty cycle permissible at rated torque.
 Higher torque at lower duty cycle on request.
 Lifetime on request.
 Other gear ratios on request.

Dimensions

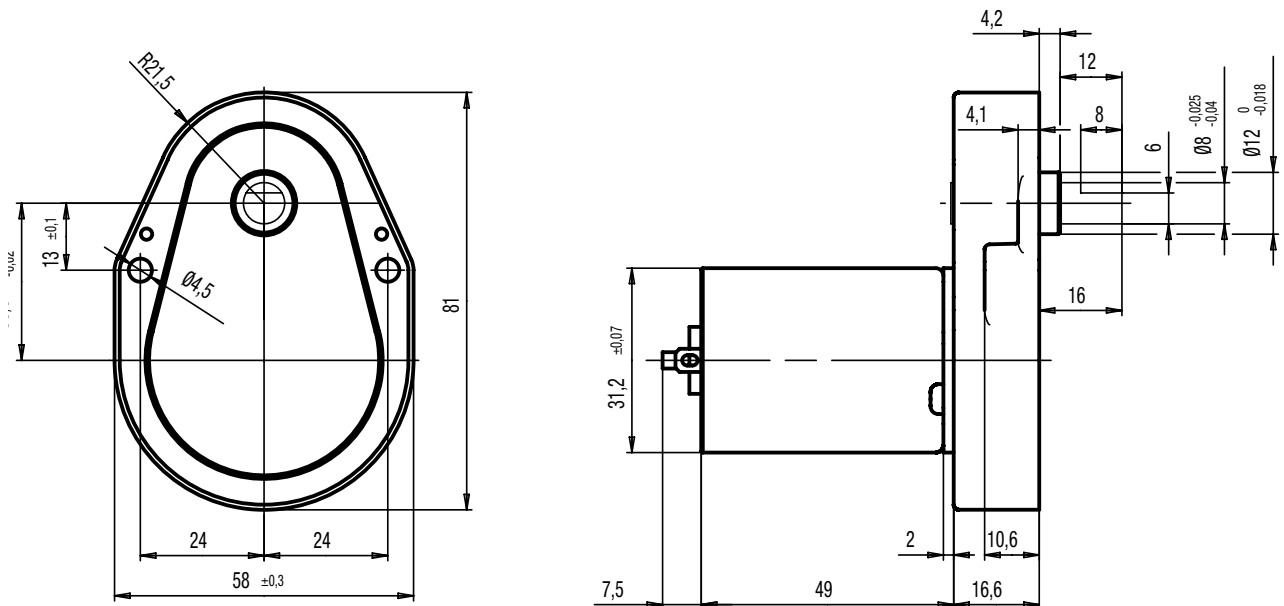

Gearbox UGO with BLDC Motor E9IDS



Voltage (Vdc)	24
Max. torque (cNm)	600
Characteristics	Driver electronics integrated inside motor
Options	Closed loop speed control Brake feature by relay shortcut circuit

Standard Data

Ambient temperature operation	°C 0 ... +50
Ambient temperature storage	°C -20 ... +80
Rotor stalling	not permissible
Approval	standard
Electrical connection	connector at motor
Mounting	any position
Weight	500 – 600 g
Axial thrust	30 N
Lateral force	80 N
Output shaft	∅ 8 × 25 mm (others on request)
Slipping clutch	no
Bearings	bronze

Order Reference

Motor type	JP	BLDC Motor (brushed)	JP	9	B	N	M4	O	75C	A	N	N
Motor size	9	diameter 50 mm										
Motor version	B	24 V; no-load speed 5900 rpm										
Approval	N	standard										
Voltage	M4	24Vdc										
Gearbox size	O											
Gear ratio	75C	750										
Connection	N	lead wires										
	A	with connector at motor										
Slipping clutch	N	without slipping clutch										
Shaft end	N	standard shaft ∅ 8 × 25, others on request										

All specifications are representative only and maybe subject to variation. For confirmation of values, please contact Johnson Electric.
Please also read "Saia Motors Important Notes" on catalog or at www.johnsonelectric.com/SaiaMotorsNotes

Technical Data

Motor JP2A

Voltage supply	V	24
No-load motor speed	rpm	5900
Rated motor speed	rpm	4600
Rated motor current	mA	850
Rated motor torque	cNm	3.0

Gear ratio		18.75	37.5	62.5	93.75	125	187.5	375	750
Rated output speed	rpm	240	120	74	48	37	24	12	6
Rated output torque	cNm	40	80	120	170	230	340	600	600

All values approximate. Speed tolerance on request.
 Output torque permissible max. 600cNm.
 Continuous duty cycle permissible at rated torque.
 Higher torque at lower duty cycle on request.
 Lifetime on request.
 Other gear ratios on request.

Dimensions

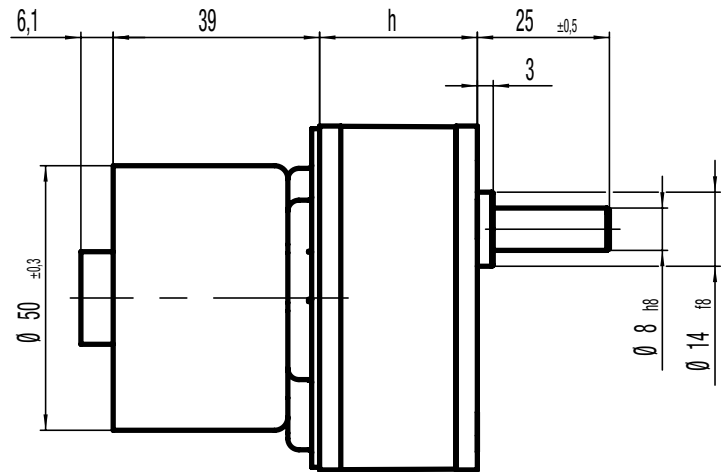
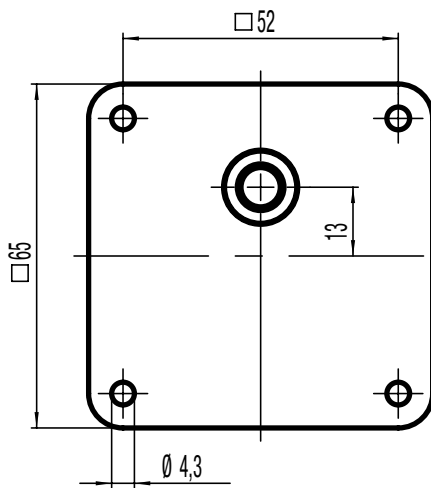

$h = 29,8$ (ratio max. 187,5)
 $h = 38$ (ratio >187,5)

Gearbox UGP with DC Motor HC785G

Voltage (Vdc) 24

Max. torque
(cNm) 600



Standard Data

Ambient temperature operation	°C 0 ... +50
Ambient temperature storage	°C -20 ... +80
Rotor stalling	not permissible
Approval	standard
Electrical connection	terminals
Mounting	any position
Weight	500 – 600 g
Axial thrust	30 N
Lateral force	80 N
Output shaft	∅ 8 × 25 mm (others on request)
Slipping clutch	no
Bearings	bronze

Order Reference

Motor type	JP	DC Motor (brushed)	JP	7	B	N	M4	P	37C	N	N	N
Motor size	7	diameter 42 mm										
Motor version	B	24 V; no-load speed 4500 rpm										
Approval	N	standard										
Voltage	M4	24 Vdc										
Gearbox size	P											
Gear ratio	37C	375										
Connection	N	terminals, without lead wire										
	A	with lead wire and connector (on request)										
Slipping clutch	N	without slipping clutch										
Shaft end	N	standard shaft ∅ 8 × 25, others on request										

All specifications are representative only and maybe subject to variation. For confirmation of values, please contact Johnson Electric.
Please also read "Saia Motors Important Notes" on catalog or at www.johnsonelectric.com/SaiaMotorsNotes

Technical Data

Motor JP7B

Voltage supply	V	24
No-load motor speed	rpm	4500
Rated motor speed	rpm	3800
Rated motor current	mA	900
Rated motor torque	cNm	3.5

Gear ratio		18.75	37.5	62.5	93.75	125	187.5	375	750
Rated output speed	rpm	200	100	60	40	30	20	10	5
Rated output torque	cNm	45	90	140	200	270	400	600	600

All values approximate. Speed tolerance on request.
 Output torque permissible max. 600cNm.
 Continuous duty cycle permissible at rated torque.
 Higher torque at lower duty cycle on request.
 Lifetime on request.
 Other gear ratios on request.

Dimensions

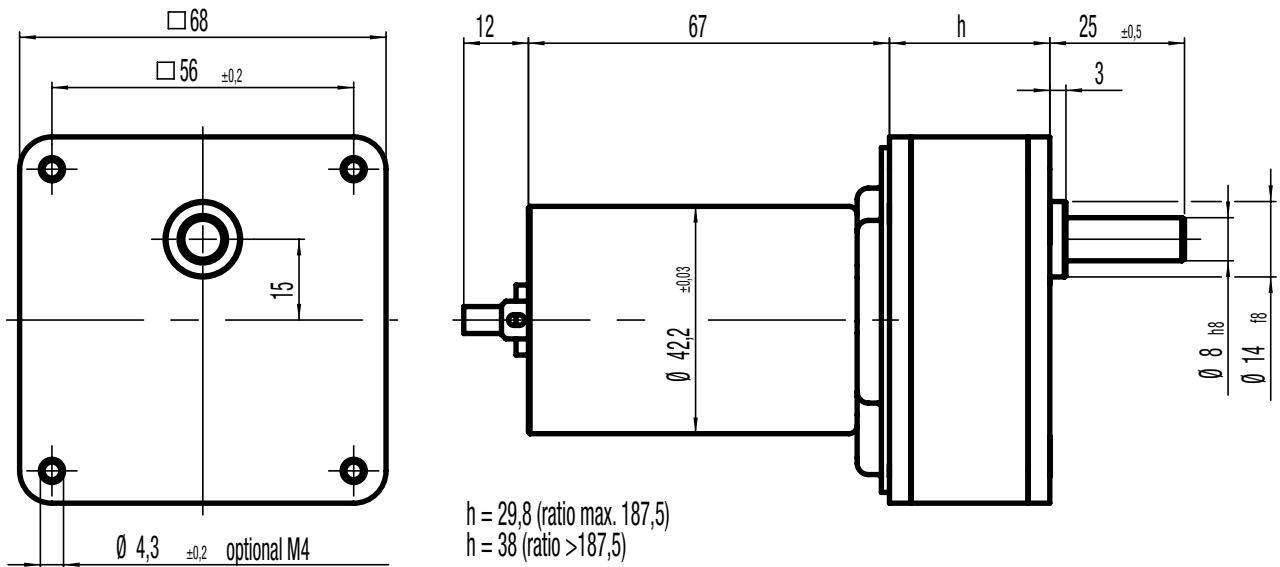

Synchronous Motors Linear

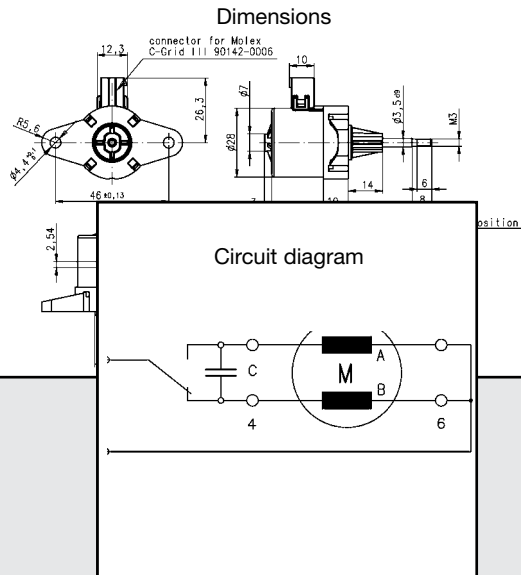

UCC1/7

Dimensions (mm)	∅ 28 x 31
Travel (mm)	10/13
Voltage (V) **	12–230
Speed (mm/s)	
50 Hz	4.16
60 Hz	5
Max. Force (N)*	48



* Depends on winding, frequency and lifetime required. Values for connector versions (C, D) / lead wire versions (N) up to 20 % lower. Drive against end stops only permissible after clarification of operating conditions and approval by Saia motors. Radial forces on the shaft will reduce life time and performance.

** regard circuit diagram and connector type

Note: All force and power output values are minimum values, at rated voltage and motor temperature 23°C.

Standard Data

Climatic class	wide-spread according to DIN IEC 60721-2-1 : 2015
Ambient temperature operation	°C -15 ... +60
Ambient temperature storage	°C -20 ... +100
Thermal resistance at f=0 R _{therm}	29 K/W
Thermal class	130 (B) according to DIN EN 60085 : 2008
Winding coil temperature increase	K 60
Approval	standard
Mounting	any position
Electrical connection	connector type C, D, N
Protection	IP40 according to DIN EN 60529 : 2014
Weight	67 g
Rotor stalling	motor can be stopped when voltage is applied, without being overheated
Bearings	ball bearing

Order Reference

Type	Synchronous Motor	UCC	13	N	B4	D	1B
Configuration	13 standard magnet	73 stronger magnet					
Approval	N						
Voltage/frequency	see next pages						
Connection	C see next pages "Connection Types" and page 145 "Connection Types" for B						
Shaft	1B Travel 13 mm ± 0.7 mm (other standard shafts see under dimensions)						

All specifications are representative only and maybe subject to variation. For confirmation of values, please contact Johnson Electric. Please also read "Saia Motors Important Notes" on catalog or at www.johnsonelectric.com/SaiaMotorsNotes

Technical Data

Rated frequency	Hz	50		
Axial speed	mm/s	4.16		
Tolerance of voltage		standard power supply system +10% / -10%		
Linear travel max.	mm	10/13		
Axial play at ± 20 N force	mm	< 0.25		
Winding temperature T_{max}		130		
Rated voltage U_N	V	12	24	110 ¹⁾
Duty cycle	%	100	100	100
Resistance R_{20}	Ω	53	210	5000
Capacitor C_{50}	$\mu F/V \pm 10\%$	18/20	4.7/40	0.22/200
Winding code		B1	B4	C8

Circuit diagram Parallel circuit 12 V, 24 V, 48 V

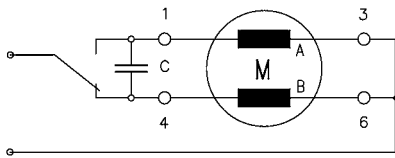

Parallel circuit 230 V (only for connector N) with 110 V motor and resistor R_V

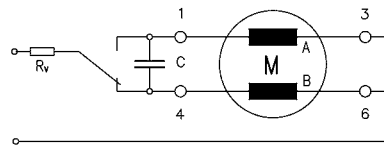

$R_V = 5.6 \text{ k}\Omega, 3 \text{ W}$

Series circuit 110 V (only for connector N)

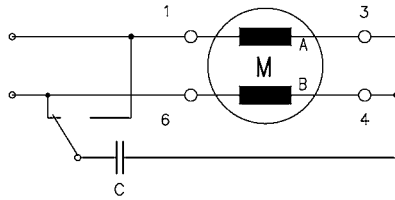

Parallel circuit 230 V (only for connector N) with 110 V motor and capacitor C_V

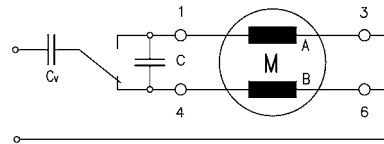

$C_V = 0.33 \mu F, 250 \text{ VAC}$

switch to

- 1 Pull (in)
- 4 Push (out)
- 6 Push (out)
(for series circuit)

¹⁾ 110 V version available with 150 mm lead wires AWG26 only
Standard versions:

Shaft type (see dimensions)	Order code
1B	UCC13NC8N1BZ4
1E	UCC13NC8N1EZ4
1S	UCC13NC8N1SZ4
1R	UCC13NC8N1RZ4
1Q	UCC13NC8N1QZ4

Dimensions Version with Connector D, with 13 mm travel, shaft 1B and 1E

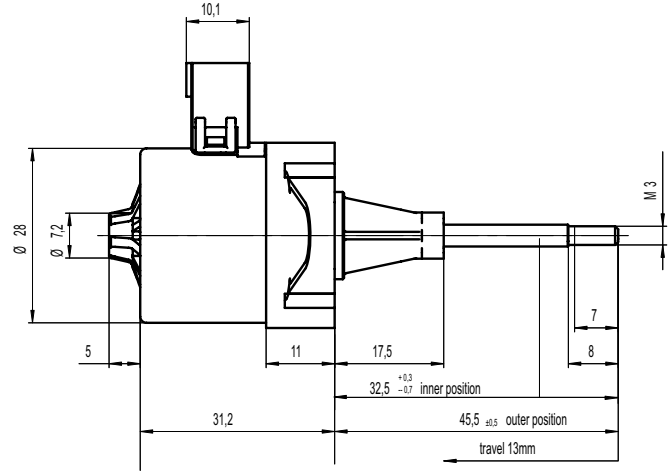
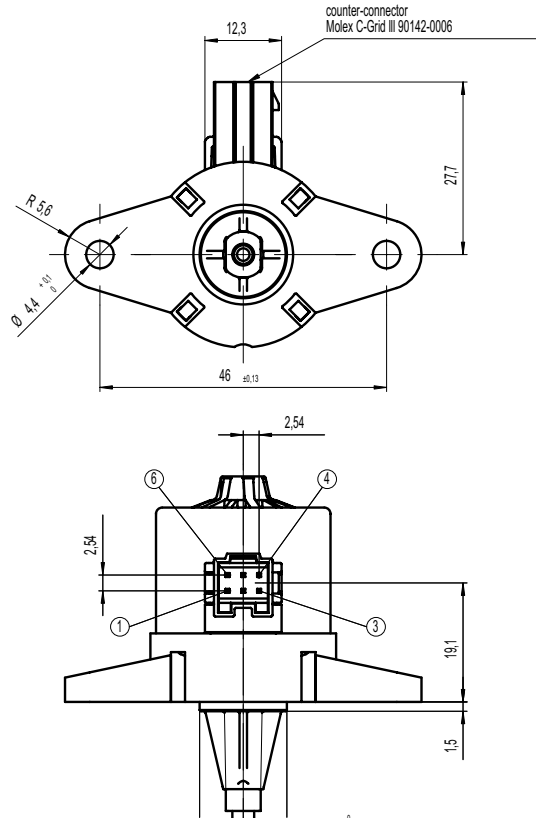

shaft 1B= cost effective solutions for forces up to 25N

Version with Connector D, with 50..150 mm travel, shaft 1R, 1S, 1Q

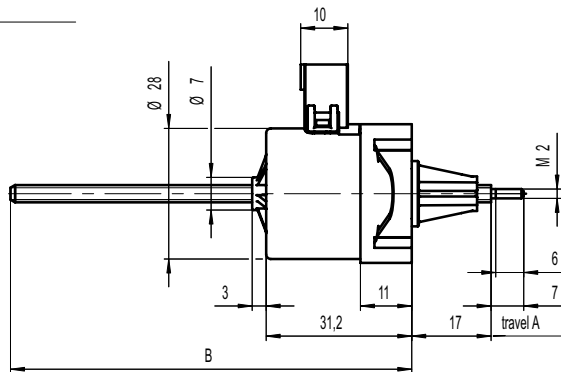
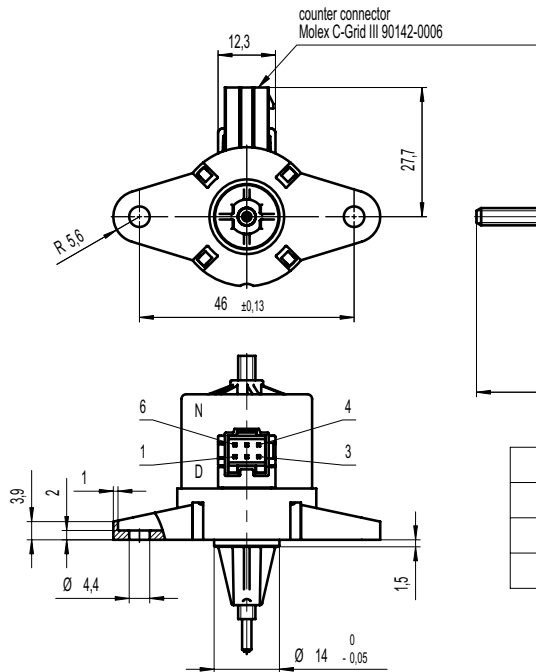

shaft	A	B
1Q	150 mm	186 mm
1R	100 mm	136 mm
1S	50 mm	86 mm

Dimensions 110 V version with lead wires

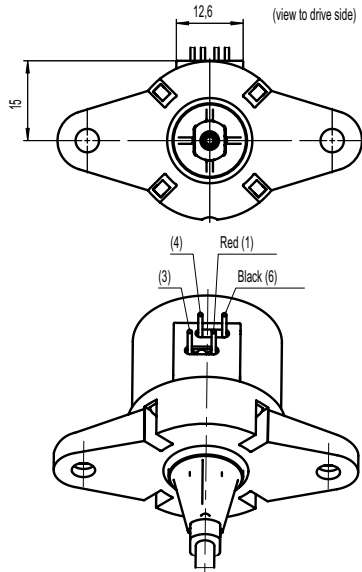

different lead colours for 110V (230V)
for rotary synchronous motors in series circuit

Force

		connector version		lead wire version	
		50 Hz	60 Hz	50 Hz	60 Hz
UCC1	100 %	33 N	35 N	26 N	29 N
	30%	39 N	41 N	31 N	34 N
UCC7	100 %	39 N	41 N	32 N	35 N
	30%	47 N	48 N	38 N	42 N

UCK 1/7

Dimensions (mm)	∅ 28 x 31
Travel (mm)	10/13
Voltage (V) **	12–230
Speed (mm/s)	
50 Hz	8.33
60 Hz	10
Max. Force (N)*	49



* Depends on winding, frequency and lifetime required. Values for connector versions (C, D) / lead wire versions (N) up to 20 % lower.
 Drive against end stops only permissible after clarification of operating conditions and approval by Saia motors.
 Radial forces on the shaft will reduce life time and performance.

** regard circuit diagram and connector type

Note: All force and power output values are minimum values, at rated voltage and motor temperature 23°C.

Standard Data

Climatic class	wide-spread according to DIN IEC 60721-2-1 : 2015
Ambient temperature operation	°C -15 ... +60
Ambient temperature storage	°C -20 ... +100
Thermal resistance at f=0 R _{therm}	29 K/W
Thermal class	130 (B) according to DIN EN 60085 : 2008
Winding coil temperature increase	K 60
Approval	standard
Mounting	any position
Electrical connection	connector type C, D, N
Protection	IP40 according to DIN EN 60529 : 2014
Weight	67 g
Rotor stalling	motor can be stopped when voltage is applied, without being overheated
Bearings	ball bearing

Order Reference

Type	Synchronous Motor	UCK	13	N	B4	D	1B
Configuration	13 standard magnet	73 stronger magnet					
Approval	N						
Voltage/frequency	see next page						
Connection	C see next pages "Connection Types" and page 145 "Connection Types" for B						
Shaft	1B Travel 13 mm ± 0.7 mm (other standard shafts see under dimensions)						

All specifications are representative only and maybe subject to variation. For confirmation of values, please contact Johnson Electric.
 Please also read "Saia Motors Important Notes" on catalog or at www.johnsonelectric.com/SaiaMotorsNotes

Technical Data

Rated frequency	Hz	50		
Speed	mm/s	8.33		
Tolerance of voltage		standard power supply system +10% / -10%		
Axial play at 20 N force	mm	< 0.25		
Duty cycle		100 %		
Winding temperature T_{max}		130		
Rated voltage U_N	V	12	24	110 ¹⁾
Duty cycle	%	100	100	100
Resistance R_{20}	Ω	59	230	5500
Capacitor C_{50}	$\mu F / V \pm 10\%$	22/20	5.6/40	0.27/200
Winding code		B1	B4	C8/H8

Circuit diagram Parallel circuit 12 V, 24 V, 48 V

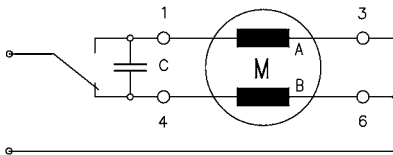

Parallel circuit 230 V (only for connector N) with 110 V motor and resistor R_V

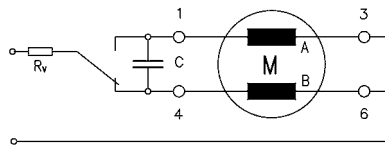

$R_V = 5.6 \text{ k}\Omega, 3 \text{ W}$

switch to

- 1 Pull (in)
- 4 Push (out)
- 6 Push (out) (for series circuit)

Series circuit 110 V (only for connector N)

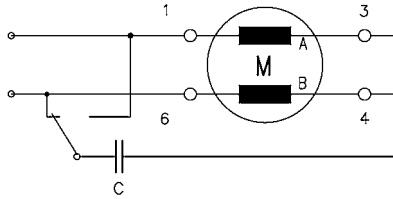

Parallel circuit 230 V (only for connector N) with 110 V motor and capacitor C_V

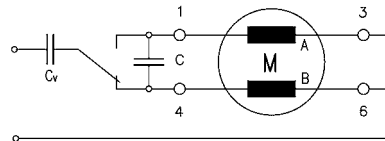

$C_V = 0.33 \mu F, 250 \text{ VAC}$

¹⁾ 110 V version available with 150 mm lead wires AWG26 only
Standard versions:

Shaft type (see dimensions)	Order code
1B	UCK13NC8N1BZ2
1E	UCK13NC8N1EZ2
1S	UCK13NC8N1SZ2
1R	UCK13NC8N1RZ2
1Q	UCK13NC8N1QZ2

Dimensions Version with Connector D, with 13 mm travel, shaft 1B and 1E

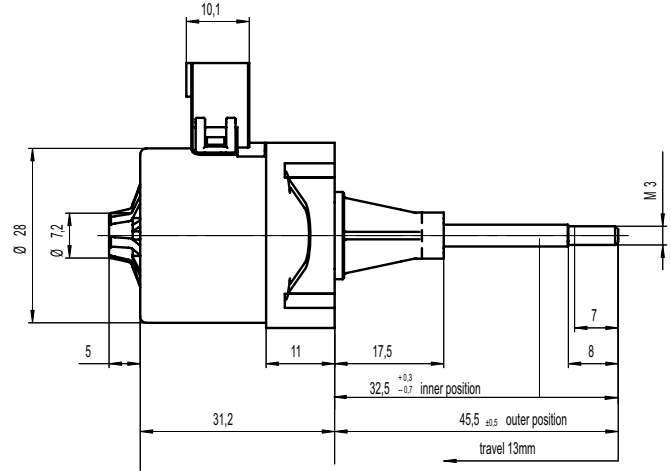
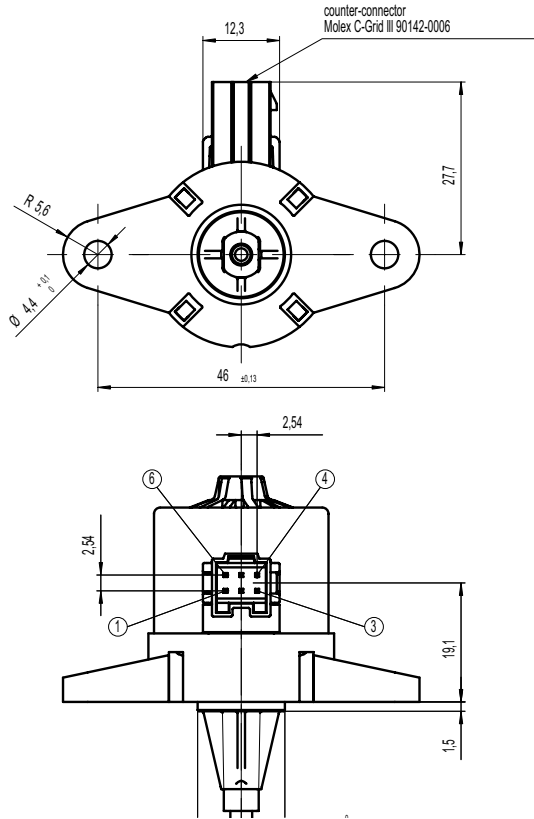

shaft 1B= cost effective solutions for forces up to 25N

Version with Connector D, with 50..150 mm travel, shaft 1R, 1S, 1Q

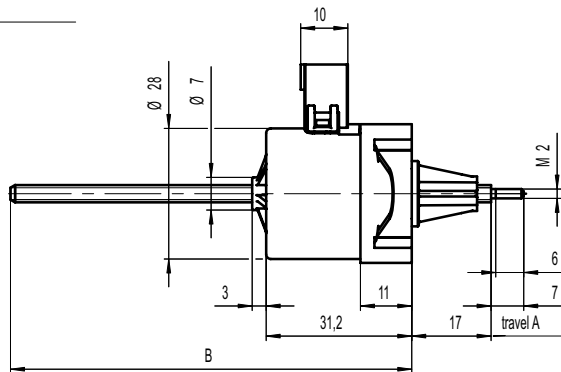
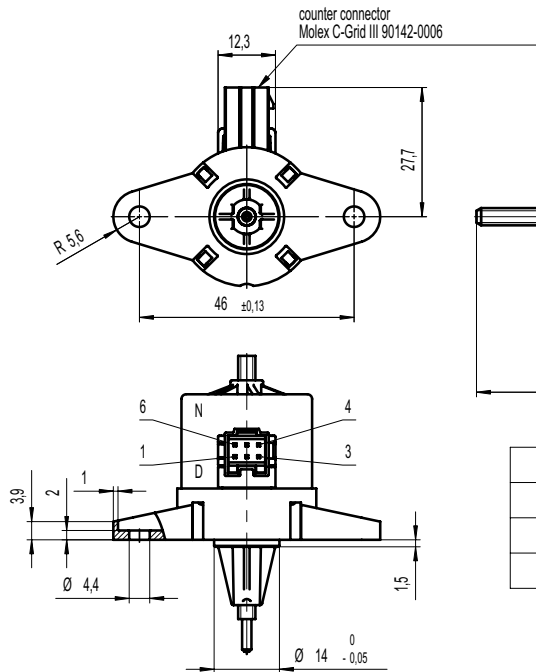

shaft	A	B
1Q	150 mm	186 mm
1R	100 mm	136 mm
1S	50 mm	86 mm

Dimensions 110 V version with lead wires

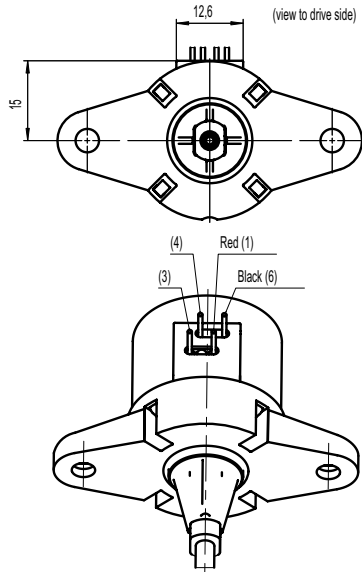

different lead colours for 110V (230V)
for rotary synchronous motors in series circuit

Force

		connector version		lead wire version	
		50 Hz	60 Hz	50 Hz	60 Hz
UCK1	100 %	27 N	28 N	19 N	19 N
	30 %	35 N	41 N	24 N	26 N
UCK7	100 %	34 N	33 N	22 N	21 N
	30 %	44 N	49 N	29 N	30 N

UAL 1/5; UAL 2

Dimensions (mm)	20 x 30
Travel (mm)	15
Travel per step (mm)	0,021
Thread pitch (mm)	0,5
Speed (mm/s) at 200 Hz	4,16
Step angle (°)	15
Max. Force (N)*	40



*Depends on winding, frequency and lifetime required.

Drive against end stops only permissible after clarification of operating conditions and approval by Saia Motor.

Radial forces on the shaft will reduce life time and performance.

Note: All force and power output values are minimum values, at rated voltage and motor temperature 23°C.

Standard Data

Climatic class	wide-spread according to DIN IEC 60721-2-1 : 2015
Ambient temperature operation	°C -15 ... +60
Ambient temperature storage	°C -20 ... +100
Thermal resistance at f=0 R _{them}	47 K/W
Thermal class	130 (B) according to DIN EN 60085 : 2008
Approval	standard
Mounting	any position
Electrical connection	lead wire with CT connector
Protection	IP40 according to DIN EN 60529 : 2014
Weight	33 g
Rotor stalling	motor can be stopped when voltage is applied, without being overheated
Bearings	ball bearing

Order Reference

Type	Stepper Motor	UAL	1E	N	01	E	1A
Configuration	1A bipolar, standard magnet, screw flange 1E bipolar, standard magnet, bayonet flange 2A unipolar, standard magnet, screw flange 2E unipolar, standard magnet, bayonet flange 5A bipolar, stronger magnet, screw flange 5E bipolar, stronger magnet, bayonet flange						
Approval	N standard						
Winding code	see next page, resistance per winding for bipolar or unipolar						
Connection	E 100 mm lead wire with CT connector						
Shaft	1A Travel 15 mm ± 0,7 mm (others on request)						

All specifications are representative only and maybe subject to variation. For confirmation of values, please contact Johnson Electric.
Please also read "Saia Motors Important Notes" on catalog or at www.johnsonelectric.com/SaiaMotorsNotes

Technical Data

Steps per mm		48
Winding temperature T_{max}	°C	130
Linear travel max.	mm	15
Axial play at 20 N force	mm	0,25

unipolar versions available upon request

bipolar	Rated voltage U_N	V	6	12	24
	Duty cycle	%	100	100	100
	Resistance R_{20}	Ω	40	150	610
	Winding code		03	01	04

* measured at 23 °C, lifetime depends on load characteristics and ambient conditions

Circuit diagram bipolar

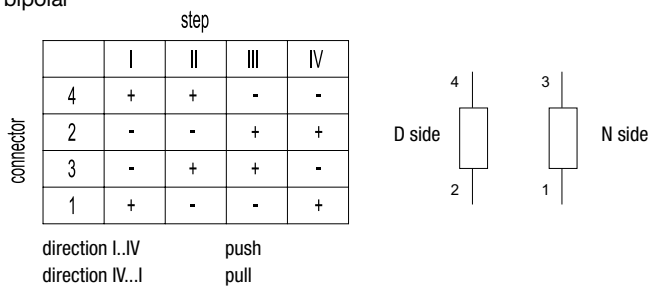

unipolar

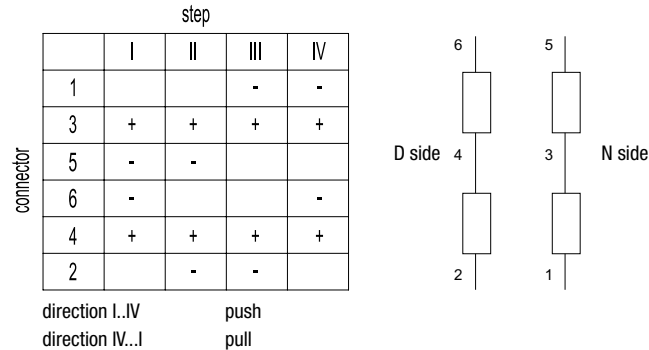

Dimensions Version with 100 mm leads and CT connector, 15 mm travel

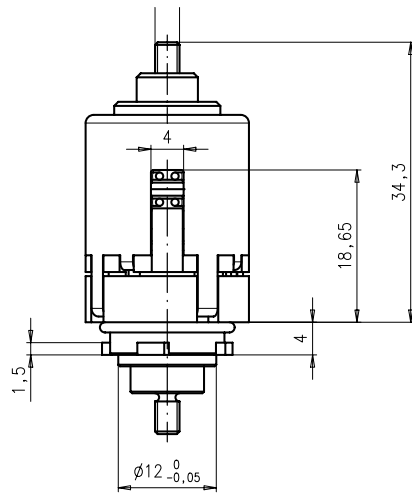
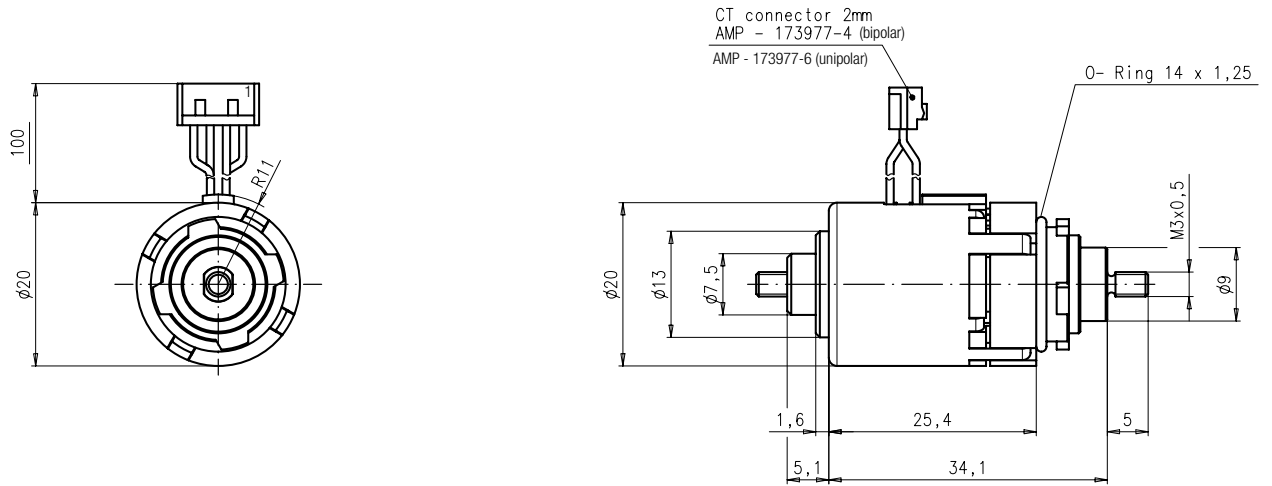

Connecting dimensions of direct bayonet mount

Material thickness 1,5 mm

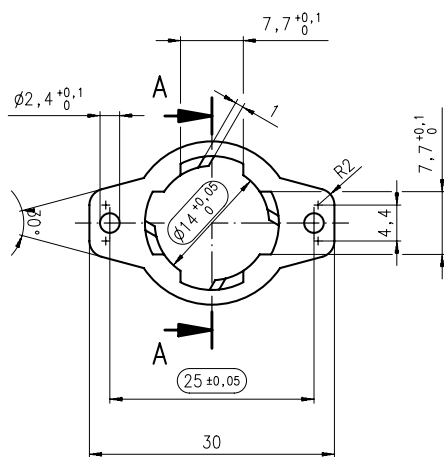
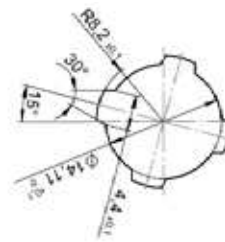

Performance Chart

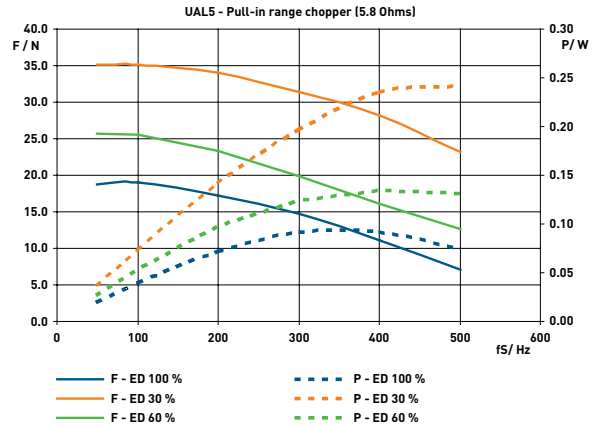
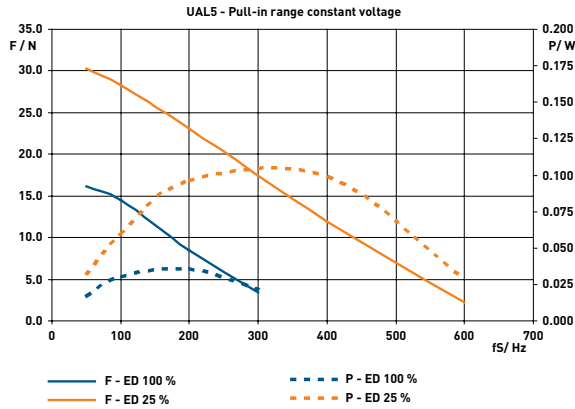
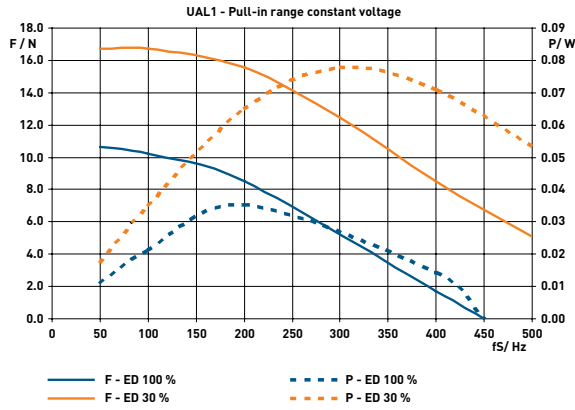

100% duty cycle: max. current per phase 300 mA
 60% duty cycle: max. current per phase 360 mA
 30% duty cycle: max. current per phase 500 mA

UCE1/7; UCE2/8

Dimensions (mm)	∅ 28 x 31
Travel (mm)	10/13
Travel per step (mm)	0.021
Speed (mm/s) at 200 Hz	4.16
Max. Force (N)*	80



*Depends on winding, frequency and lifetime required.
 Drive against end stops only permissible after clarification of operating conditions and approval by Saia Motors.
 Radial forces on the shaft will reduce life time and performance.
 Note: All force and power output values are minimum values, at rated voltage and motor temperature 23°C.

Standard Data

Climatic class	wide-spread according to DIN IEC 60721-2-1 : 2015
Ambient temperature operation	°C -15 ... +60
Ambient temperature storage	°C -20 ... +100
Thermal resistance at f=0 R _{therm}	29 K/W
Thermal class	130 (B) according to DIN EN 60085 : 2008
Approval	standard
Mounting	any position
Electrical connection	connector type C, D
Protection	IP40 according to DIN EN 60529 : 2014
Weight	67 g
Rotor stalling	motor can be stopped when voltage is applied, without being overheated
Bearings	ball bearing

Order Reference

Type	Stepper Motor	UCE	13	N	01	D	1B
Configuration	13 bipolar, standard magnet	73 bipolar, stronger magnet					
	23 unipolar, standard magnet	83 unipolar, stronger magnet					
Approval	N						
Resistance	see next page, Resistance per winding for bipolar or unipolar						
Connection	C see next pages "Connection Types" and page 145 "Connection Types" for B						
	D						
Shaft	1B Travel 13 mm ± 0.7 mm (other standard shafts see under dimensions)						

All specifications are representative only and maybe subject to variation. For confirmation of values, please contact Johnson Electric.
 Please also read "Saia Motors Important Notes" on catalog or at www.johnsonelectric.com/SaiaMotorsNotes

Technical Data

bipolar	Rated voltage U_N :	V	6	12	24
	Resistance per winding R_{20}	Ω	24	90	380
Travel per step		mm	0.021		
Winding temperature T_{max}		$^{\circ}C$	130		
Axial play at ± 20 N force		mm	< 0.25		

Circuit diagram bipolar

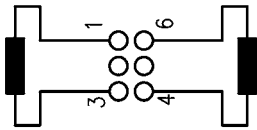

stepping sequence number

	I	II	III	IV	I
1	+	+	-	-	+
3	-	-	+	+	-
4	-	+	+	-	-
6	+	-	-	+	+

pin number

→ Pull in (step I to IV, I to IV, etc.)
← Push out (step IV to I, step IV to I, etc.)

unipolar

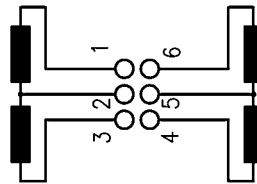

stepping sequence number

	I	II	III	IV	I
1	-	-			-
2	+	+	+	+	+
3			-	-	
4		-	-		
5	+	+	+	+	+
6	-			-	-

pin number

→ Pull in (step I to IV, I to IV, etc.)
← Push out (step IV to I, step IV to I, etc.)

Dimensions

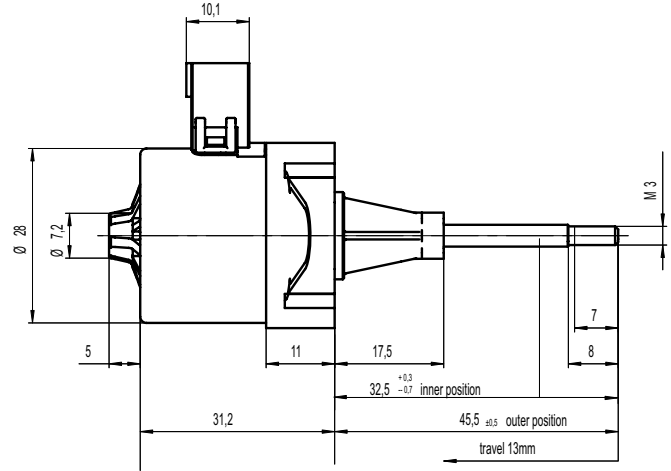
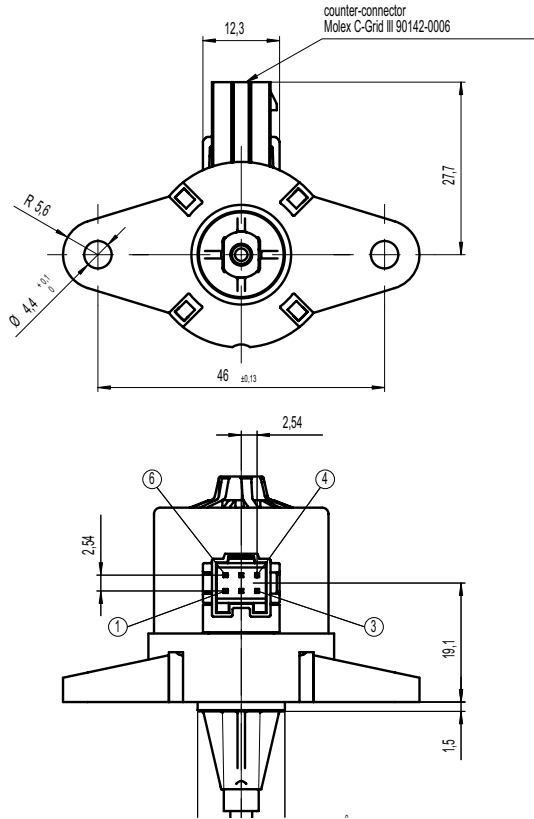

shaft 1B= cost effective solutions for forces up to 25N

Version with Connector D, with 50..150 mm travel, shaft 1R, 1S, 1Q

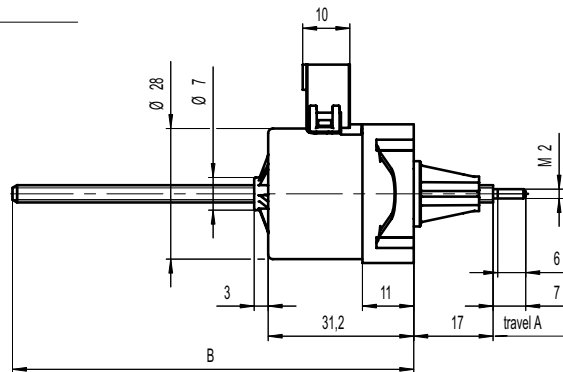
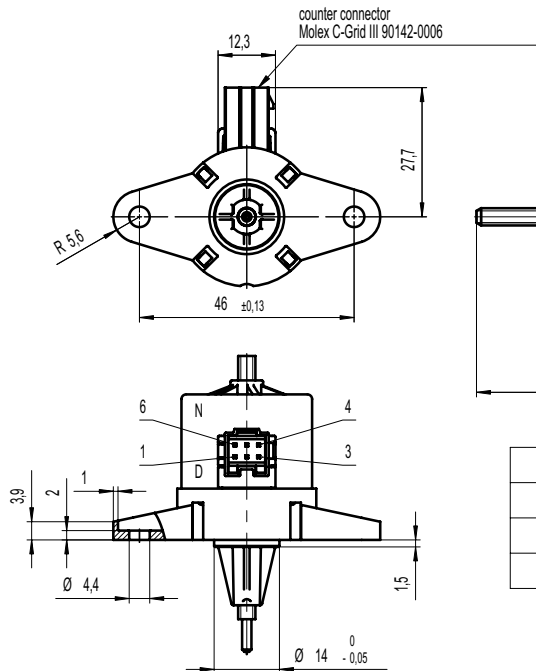

shaft	A	B
1Q	150 mm	186 mm
1R	100 mm	136 mm
1S	50 mm	86 mm

Performance Chart

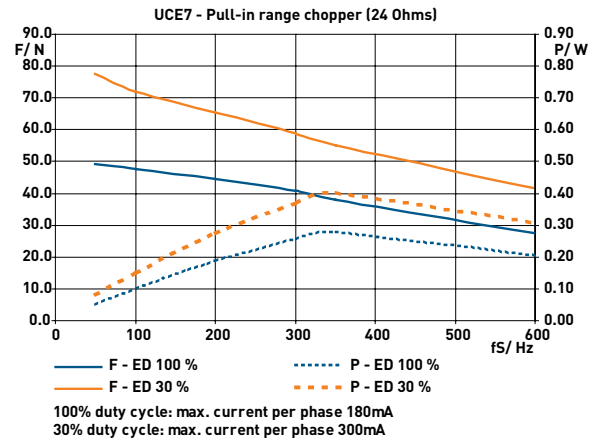
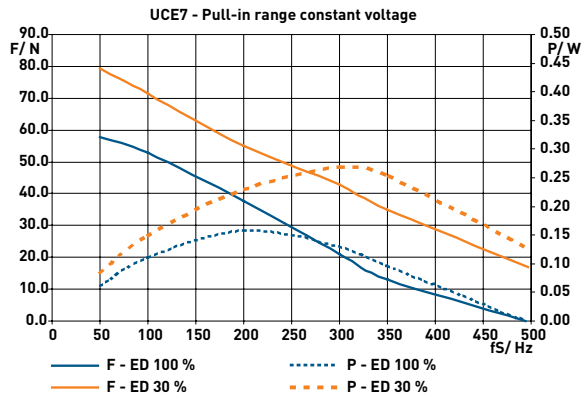
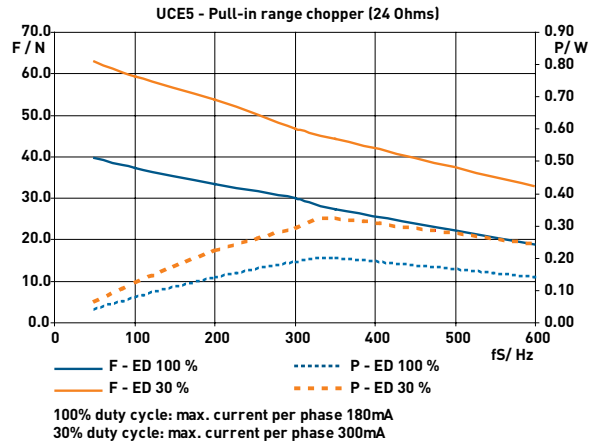
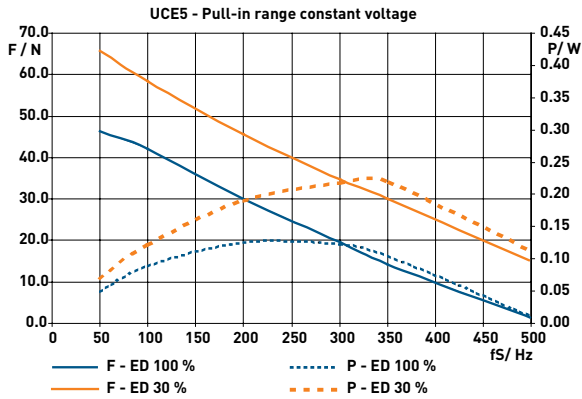
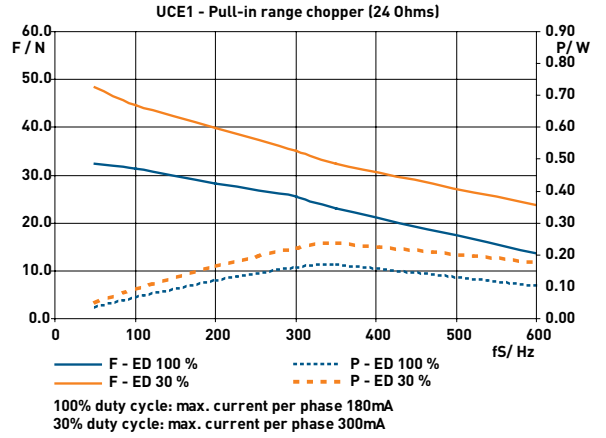
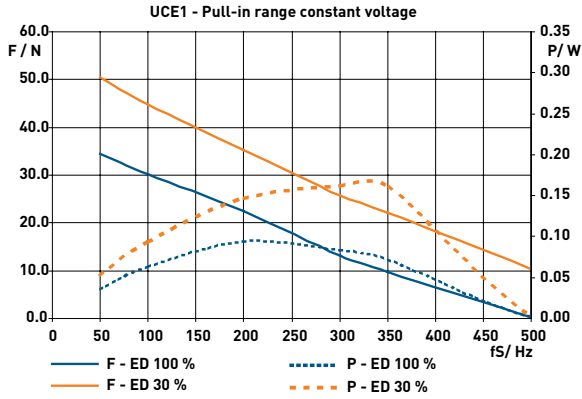

Performance Chart

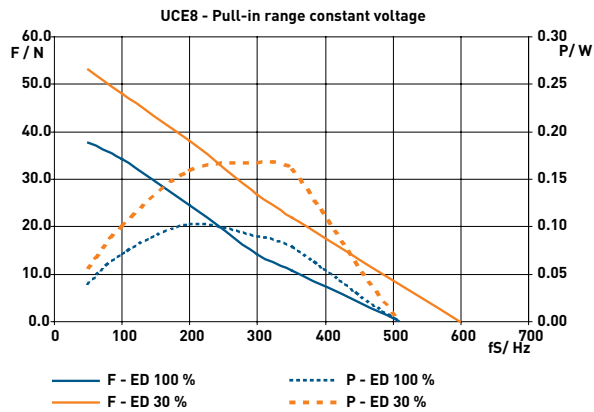
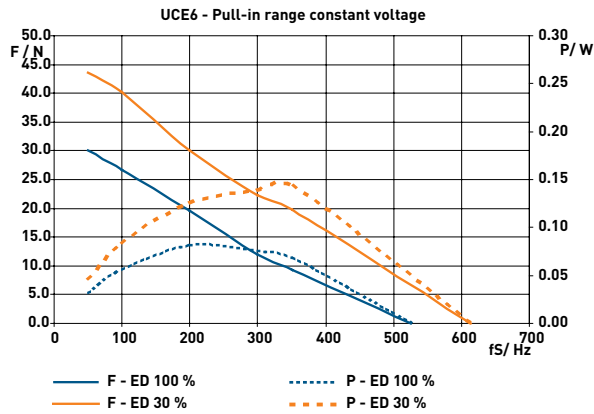
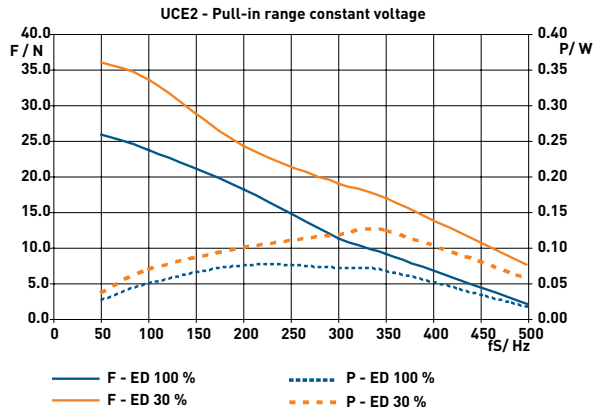

UCL1/7; UCL2/8

Dimensions (mm)	∅ 28 x 31
Travel (mm)	10/13
Travel per step (mm)	0.041
Speed (mm/s) at 200 Hz	8.33
Max. Force (N)*	70



*Depends on winding, frequency and lifetime required.
 Drive against end stops only permissible after clarification of operating conditions and approval by Saia Motors.
 Radial forces on the shaft will reduce life time and performance.
 Note: All force and power output values are minimum values, at rated voltage and motor temperature 23°C.

Standard Data

Climatic class	wide-spread according to DIN IEC 60721-2-1 : 2015
Ambient temperature operation	°C -15 ... +60
Ambient temperature storage	°C -20 ... +100
Thermal resistance at f=0 R _{therm}	29 K/W
Thermal class	130 (B) according to DIN EN 60085 : 2008
Approval	standard
Mounting	any position
Electrical connection	connector type C, D
Protection	IP40 according to DIN EN 60529 : 2014
Weight	67 g
Rotor stalling	motor can be stopped when voltage is applied, without being overheated
Bearings	ball bearing

Order Reference

Type	Stepper Motor				UCL	13	N	01	D	1B
Configuration	13	bipolar, standard magnet	73	bipolar, stronger magnet						
	23	unipolar, standard magnet	83	unipolar, stronger magnet						
Approval	N									
Resistance	see next page, Resistance per winding for bipolar or unipolar									
Connection	C see pages 151, „Connection Types“ D									
Shaft	1B Travel 13 mm ± 0.7 mm (other standard shafts see under dimensions)									

All specifications are representative only and maybe subject to variation. For confirmation of values, please contact Johnson Electric.
 Please also read "Saia Motors Important Notes" on catalog or at www.johnsonelectric.com/SaiaMotorsNotes

Technical Data

bipolar	Rated voltage U_N :	V	6	12	24
	Duty cycle	%	100	100	100
	Resistance R_{20}	Ω	24	90	380
	Winding code		05	02	01
unipolar	Rated voltage U_N :	V	6	12	24
	Duty cycle	%	100	100	100
	Resistance R_{20}	Ω	24	90	380
	Winding code		07	08	01
	Travel per step	mm	0.042		
	Winding temperature T_{max}	$^{\circ}\text{C}$	130		
	Axial play at ± 20 N force	mm	< 0.25		

Circuit diagram bipolar

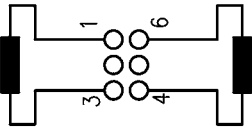

stepping sequence number

	I	II	III	IV	I
pin number 1	+	+	-	-	+
pin number 3	-	-	+	+	-
pin number 4	-	+	+	-	-
pin number 6	+	-	-	+	+

→ Pull in (step I to IV, I to IV, etc.)
← Push out (step IV to I, step IV to I, etc.)

unipolar

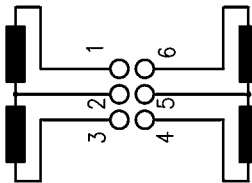

stepping sequence number

	I	II	III	IV	I
pin number 1	-	-			-
pin number 2	+	+	+	+	+
pin number 3			-	-	
pin number 4		-	-		
pin number 5	+	+	+	+	+
pin number 6	-			-	-

→ Pull in (step I to IV, I to IV, etc.)
← Push out (step IV to I, step IV to I, etc.)

Dimensions Version with Connector D, with 13 mm travel, shaft 1B and 1E

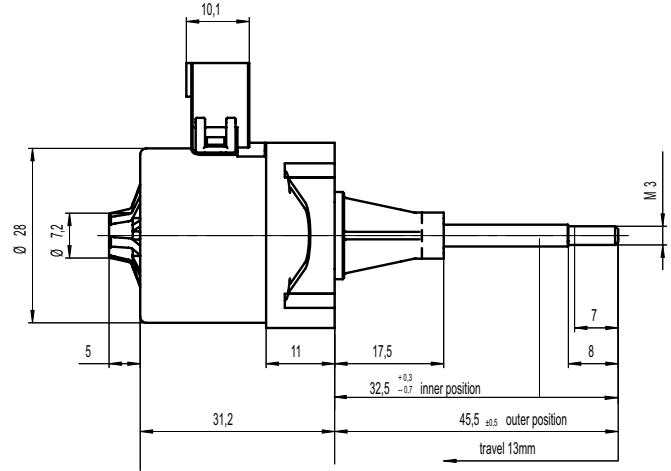
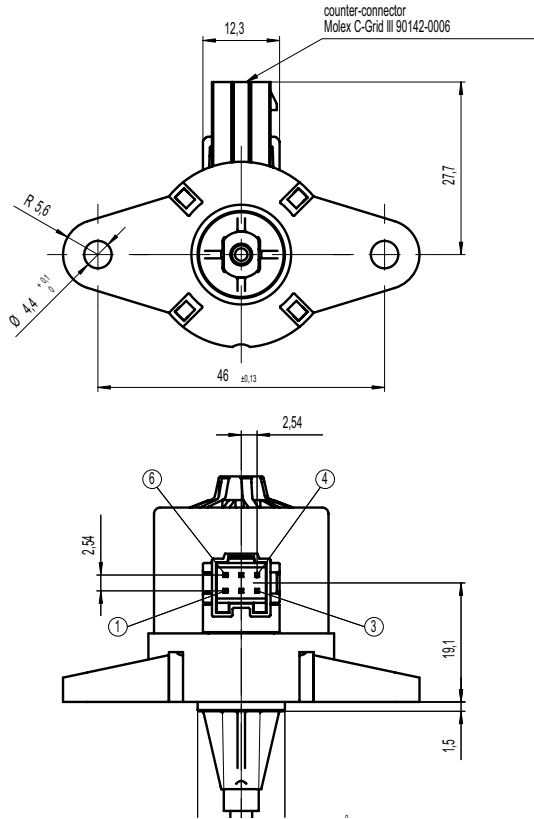

shaft 1B= cost effective solutions for forces up to 25N

Version with Connector D, with 50..150 mm travel, shaft 1R, 1S, 1Q

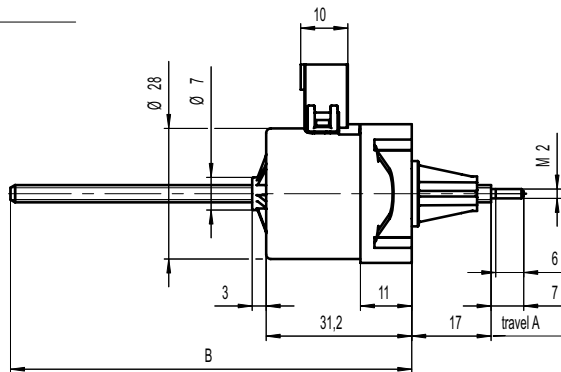
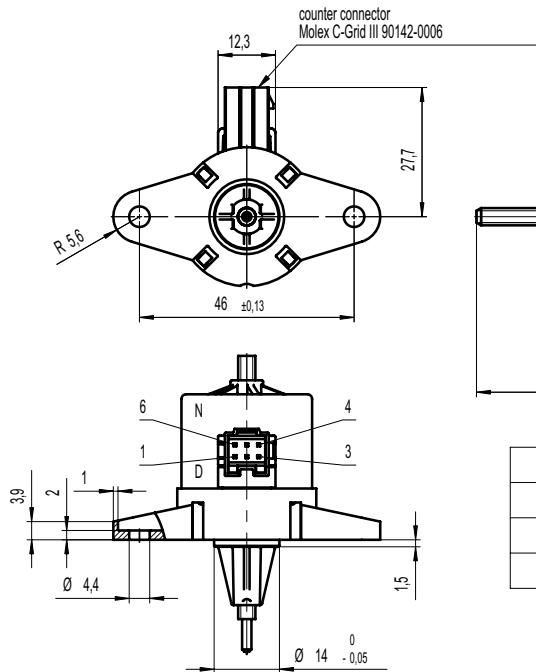

shaft	A	B
1Q	150 mm	186 mm
1R	100 mm	136 mm
1S	50 mm	86 mm

Performance Chart

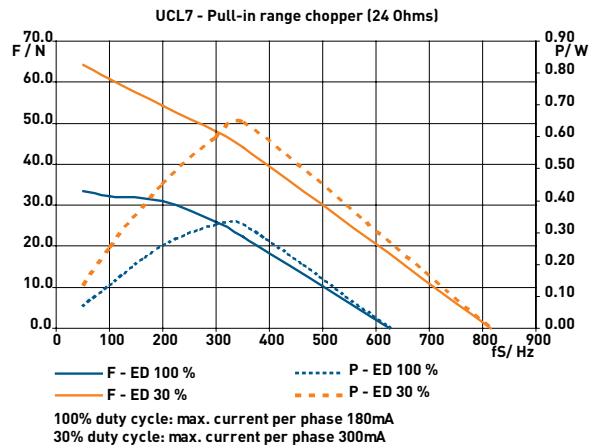
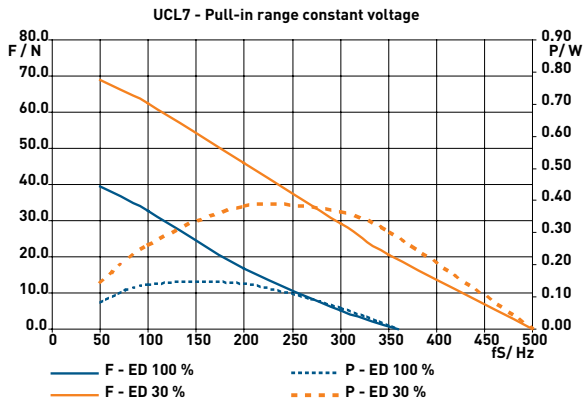
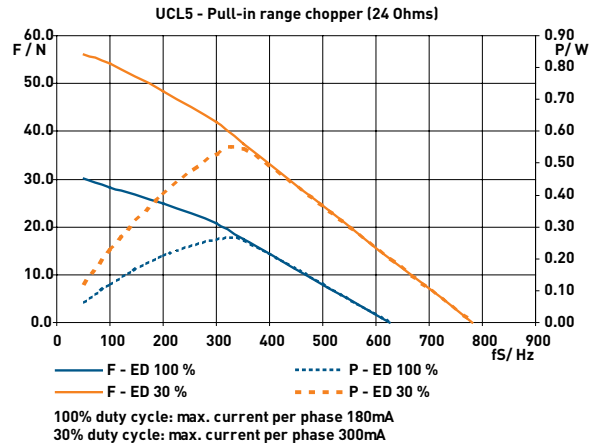
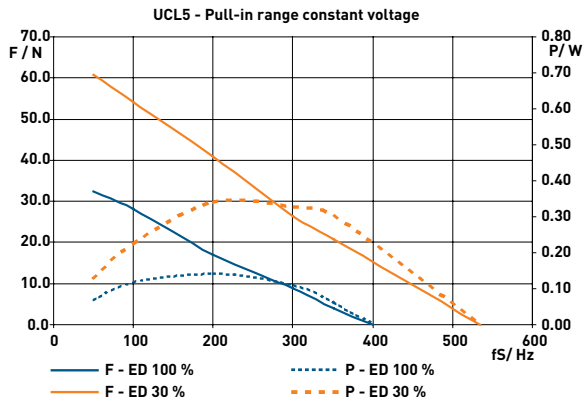
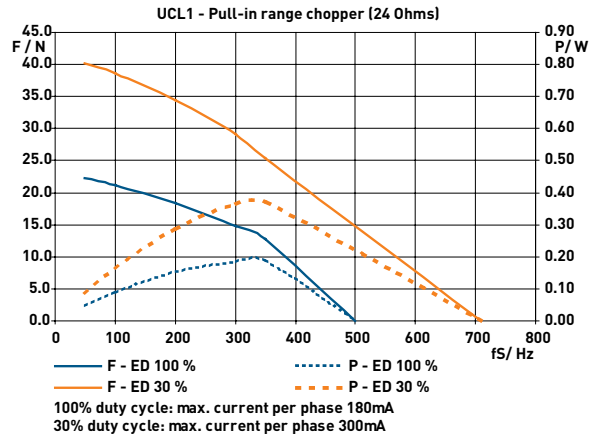
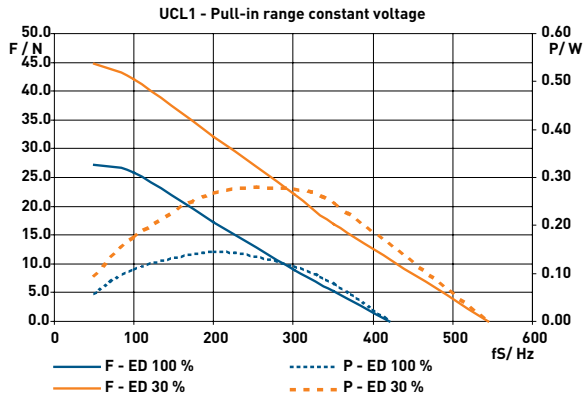

Performance Chart

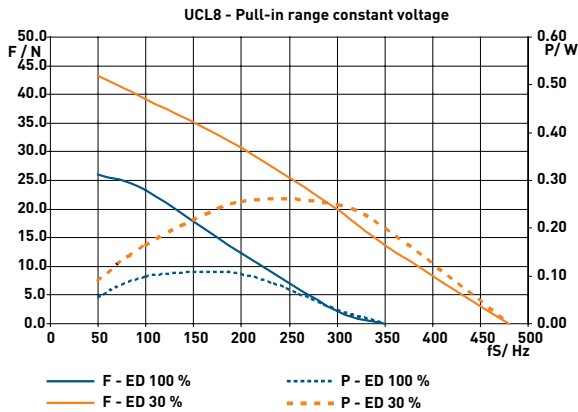
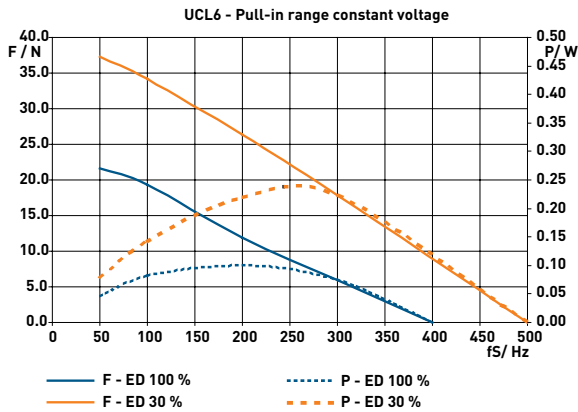
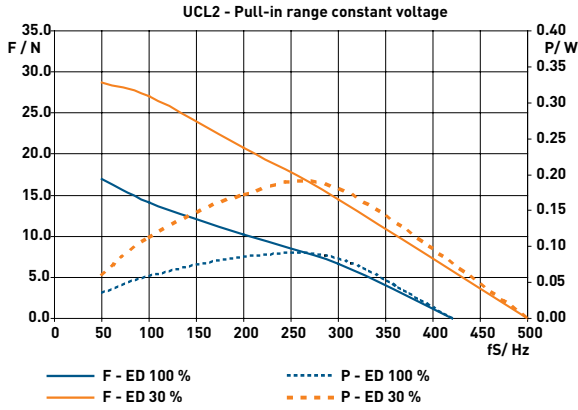

Connection Types UC motors

Connector B
for Molex Mini-Grid 51110-0660

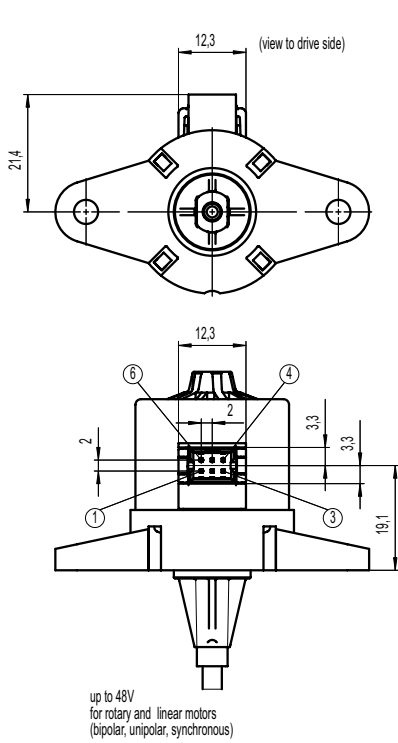

Connector C
for Tyco Modu IV 0-1740209-6

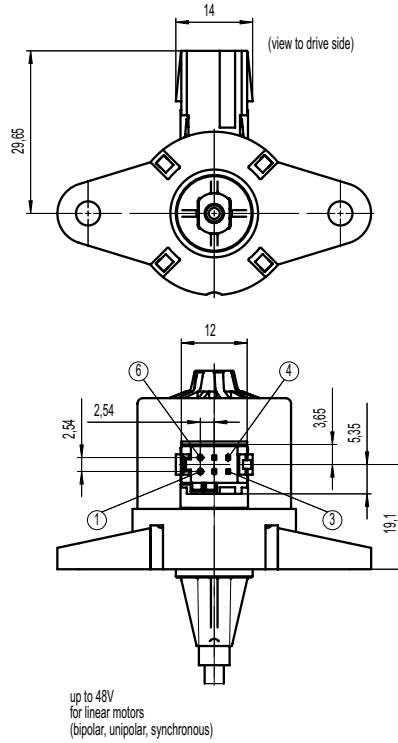

Connector D
for Molex C-Grid III 90142-0005

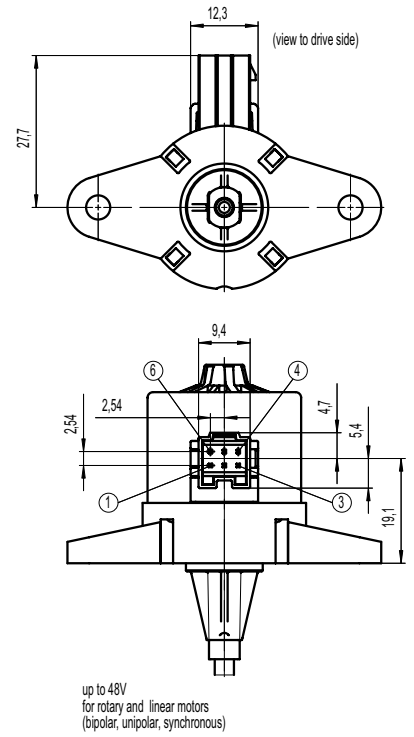

SAMOTRONIC101

Driver	for unipolar motors
Dimensions (mm)	55 x 40
Supply voltage (VDC)	10-24
Motor current	constant voltage drive
Step mode	full/half step
Clock source	internal or external
Control inputs to	<ul style="list-style-type: none"> ■ inhibit internal clock ■ inhibit motor current ■ change direction of rotations
Configuration	via DIP-switch, potentiometer



Preferred Range

Ordering Reference	
4 636 6608 0	If motors are also to be ordered please state: "with MTA-100 receptacles for use with SAMOTRONIC101".
4 636 6608 3	with screw terminal for motor connection, max 0.5 mm ²

Technical Data

Supply voltage	10-24 VDC
Phase current	≤ 350 mA
Control signal level	LS-TTL (0-5V) for all control inputs
Internal clock	50-360 Hz
External clock	up to 2 kHz
Dimensions	55 x 40 mm
Operating temperature	-5 to +50 °C
Storage temperature	-20 to +70 °C

Dimensions

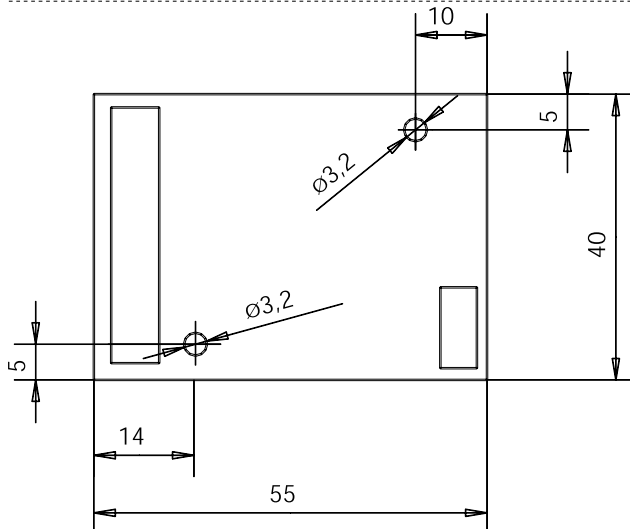

For latest technical and safety compliance information regarding these products, please download the relevant data sheet from our web site: www.saia-burgess.com/drivers

All specifications are representative only and maybe subject to variation. For confirmation of values, please contact Johnson Electric. Please also read "Saia Motors Important Notes" on catalog or at www.johnsonelectric.com/SaiaMotorsNotes

SAMOTRONIC102

Driver	for bipolar motors
Dimensions (mm)	84 x 54
Supply voltage (VDC)	<ul style="list-style-type: none"> ■ standard version 10 DC-24 ■ enhanced version 10 DC-42
Motor current	<ul style="list-style-type: none"> ■ constant current drive (chopper controlled) ■ adjustable via potentiometer
Step mode	full/half step
Clock source	internal or external
Control inputs to	<ul style="list-style-type: none"> ■ inhibit internal clock ■ inhibit motor current ■ change direction of rotations
Configuration	via DIP-switch, potentiometer
Test pins	<ul style="list-style-type: none"> ■ motor current ■ step frequency



Preferred Range

Ordering Reference

4 636 6733 0	10-24VDC supply voltage (standard version)
4 636 6733 3	10-42VDC supply voltage (enhanced version)

If motors are also to be ordered please state: "with MTA-100 receptacles for use with SAMOTRONIC102".

Technical Data

Supply voltage	10-24 (42)VDC
Phase current	71-500 mA, on request max. 735mA/ph
Chopper frequency	typ. 20kHz
Control signal level	LS-TTL (0-5V) for all control inputs
Internal clock	50-1325 Hz
External clock	up to 2 kHz
Dimensions	84 x 54 mm
Operating temperature	-20 to +60 °C
Storage temperature	-20 to +80 °C

Dimensions

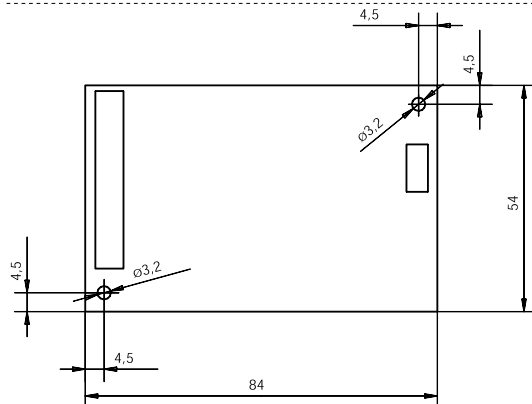

For latest technical and safety compliance information regarding these products, please download the relevant data sheet from our web site: www.saia-burgess.com/drivers

All specifications are representative only and maybe subject to variation. For confirmation of values, please contact Johnson Electric. Please also read "Saia Motors Important Notes" on catalog or at www.johnsonelectric.com/SaiaMotorsNotes

Evaluation-Kit 2

Evaluation-Kit 2

Driver	for unipolar and bipolar motors
Dimensions (mm)	metal case 164 x 130 x 45
Motor voltage (VDC)	3-48 Unipolar motors
(VAC)	8-48 Bipolar motors (< 8 on request)
Motor current	constant voltage drive and constant current drive (chopper controlled)
Step mode	full/half/micro step
Clock source	internal, programmable
Control inputs to	<ul style="list-style-type: none">■ 3 digital inputs■ 4 signal outputs■ 1 analog input 0...10 VDC■ relay contact
Configuration	RS 232, USB



Order Reference

4 717 4898 0

Power supply (on request)

Technical Data

Supply voltage	10-48 VDC/24 VAC
Phase current	≤ up to 2.3 A
Step modes	11 (full, half, wave ... microstep)
Max. step frequency	10 kHz
PLC	max. 256 steps, 65536 loops
Operating temperature	0 ... +55 °C
Storage temperature	-20 to +80 °C

Test the Stepconf software without hardware in a special demo mode (www.saia-burgess.com/evaluationkit2).

For further information please contact your Saia-Burgess sales company or see our website www.saia-burgess.com.

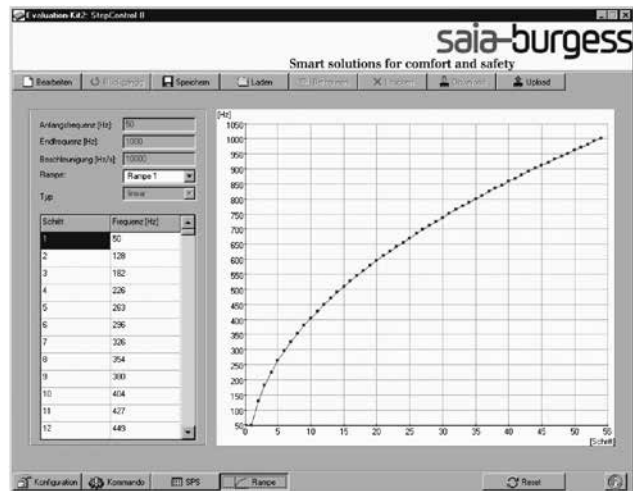

All specifications are representative only and maybe subject to variation. For confirmation of values, please contact Johnson Electric. Please also read "Saia Motors Important Notes" on catalog or at www.johnsonelectric.com/SaiaMotorsNotes

Headquarters

6/F, 12 Science Park East Avenue,
Hong Kong Science Park
Shatin, NT, Hong Kong
Phone: +852 2663 6688
e-mail: sales@johnsonelectric.com

Sales Offices (IPG)

Asia

China

No. 1, Lane 10800, Songze Avenue,
Qingpu Industrial Zone
Shanghai 201700
Phone: +86 21 6922 8256

Xin Er Industrial Zone
Shajing Town, Baoan District
Shenzhen 518125
Phone: +86 755 2990 0437

Japan

Yaesu Dai Bldg., 6F
1-1-1 Kyobashi, Chuo-ku,
Tokyo 104-0031
Phone: +81-3 3242 3830

Singapore

20 Harbour Drive #02-02
PSA Vista
Singapore 117612
Phone: +65 6224 7570

South Korea

Fine Building, 4th Floor,
304 Sinbanpo-ro, Seocho-Ku
Seoul 137-808
Phone: +82 2 518 8347

Europe

Germany

Auf der Löbke 10
58553 **Halver**
Phone: +49 2353 911 0

Italy

Via Cadamosto 3
20094 **Corsico**, Milano
Phone: +39 02 4869 21

Switzerland

Freiburgstrasse 33
3280 **Murten**
Phone: +41 26 672 71 11

United Kingdom

Unit 5, Woodstock Way,
Baldon Business Park, **Baldon**
Tyne & Wear, NE35 9PF
Phone: +44 844 811 2130

Americas

USA

10 Progress Drive
Shelton, CT 06484
Phone: +1 203 447 5362

801 Scholz Drive
P.O. Box 427
Vandalia, OH 45377
Phone: +1 937 454 2363

Brazil

Av. Papa Joao Paulo I - 1174
Guarulhos, CEP 07170-350
Sao Paulo
Phone: +55 11 2431 5600

Johnson Electric Group

6/F, 12 Science Park East Avenue,

Hong Kong Science Park

Shatin, NT, Hong Kong

Phone: +852 2663 6688

sales@johnsonelectric.com

www.johnsonelectric.com